

Spoked Handwheels· light metal

24610.0040



Product Description

Hub machined; rim turned and mirror-finished on all sides; non-machined surfaces cleanly blasted. The non-machined, raw surfaces are blasted; together with the mirror-polished rim these handwheels are therefore showing a finish which in most cases does not require additional lacquering.

Material

Axle part

- Steel, zinc-plated by galvanization

Handwheel

- Aluminium permanent-mould casting

Assembly

Shaft-end washers EH 22270. for axial fastening.

More information

Further products

- Shaft-End Washers
- Cylindrical Handles, rotating

Drawing

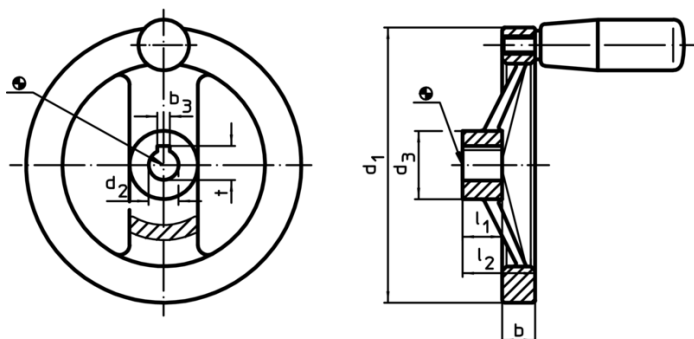

The orientation of the hub keyway may be different than shown in the drawing.

Order information

Dimensions						[g]	Art. No.
d ₁	d ₂ H7	d ₃	b	l ₁	l ₂ ~		
[mm]							
without keyway, without cylindrical handle							
250	22	48	23	28	51	1454	24610.0040