

## Handwheels· DIN 950 cast iron

24580.0011

### Product Description

Hub machined; rim turned and mirror-finished on all sides, non-machined surfaces cleanly blasted.



### Material

**Handwheel**  
• Grey cast iron GG

### Assembly

Shaft-end washers EH 22270. for axial fastening.

### More information

### Further products

- Shaft-End Washers
- Rotating Machine Handles, DIN 98

### Drawing

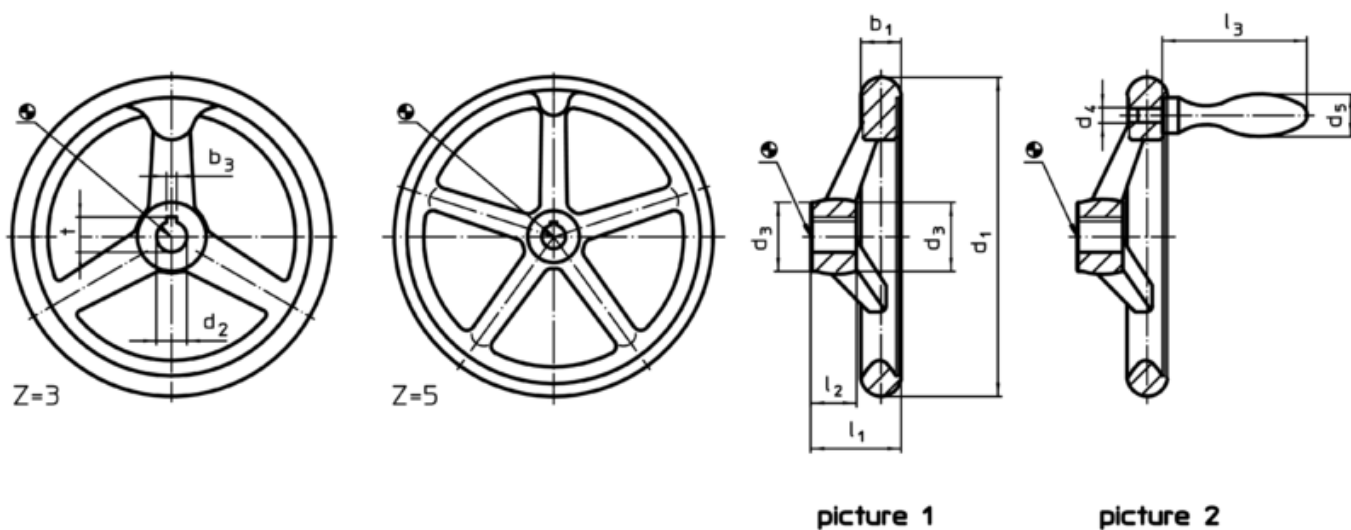

The orientation of the hub keyway may be different than shown in the drawing.

### Order information

d <sub>1</sub>	d <sub>2</sub> H7	Dimensions			l <sub>2</sub>	Number of spokes z	[g]	Art. No.
		d <sub>3</sub>	l <sub>1</sub>	~				
[mm]								
without keyway, without handle, form B-F/A (formerly: A 4) – picture 1								
125	14	28	36	18	3	720	24580.0011	

Application example

