

Shaft Clamps

23341.0012

Product Description

Shaft clamps used to clamp round workpieces, e.g. shafts, axels, tubes or rods both axially and radially.



Material

Body

- Steel, blackened

Clamping screw

- Steel, zinc-plated (DIN 912)

Assembly

1. Expand the clamping jaws to the diameter of the shaft to be clamped.
2. Insert shaft clamp into hole using the assembly tool.
3. Insert and position the shaft.
4. Clamp using cylinder screw WS (observe tightening torque).

More information

Notes

The thread d_3 serves to hold the assembly tool (optional).

Drawing

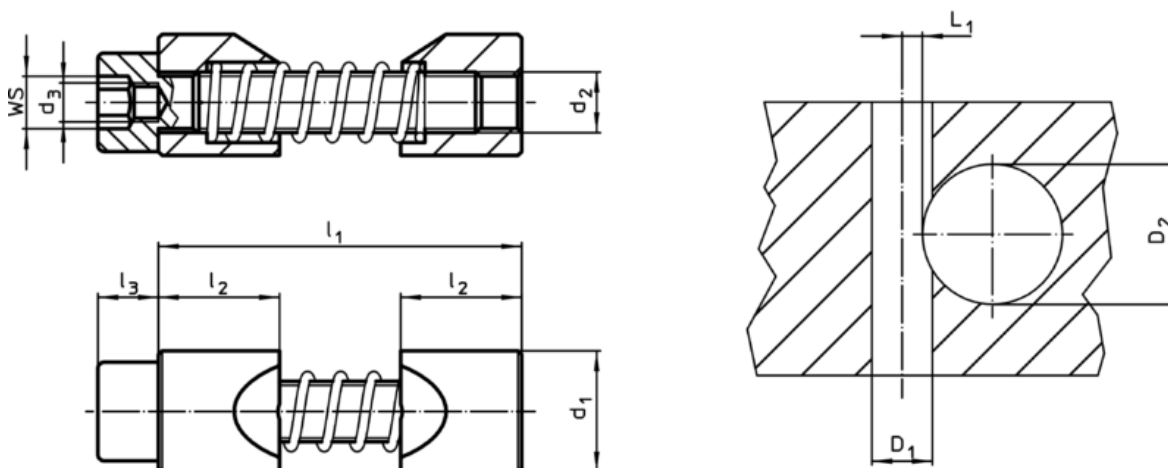

Order information

d_1 h11	d_2	Dimensions			WS	Tightening torque max.	Location hole		[g]	Art. No.		
		d_3	l_1 max.	l_2			l_3	Hub bore D_1 H7			Shaft diameter D_2	
[mm]						[Nm]	[mm]					
12	M6	M4	39	12	6	5	10	12	15 – 20	3,5	22	23341.0012

Accessories

	WS [mm]	[g]	Art. No.
special hex key			
	5	18	23341.1012

Application example

