

Centering Clamping Elements with clamping segments, operation from the bottom

23340.0122



Product Description

For centering and clamping in blind holes of workpieces with locating hole. Exact self-centering with a precision of $\pm 0,025$ mm. Components with raw or machined surface can be centered positively and are pulled down on the contact points due to the ground clamping elements. The centering clamping element is characterised by large setting ranges and a compact construction height.

Mounting from either top or bottom.

Material

Body

- Tool steel, hardened, blackened

Spring

- Stainless steel

Clamping segments

- Stainless steel 1.4112, hardened and ground

Assembly

Assembly instruction for mounting from the top: Take-off clamping plate and screw. Fasten body by means of threaded pin via WS₂.

Operation

Operation from bottom manually or automatically with either pneumatic or hydraulic actuation.

More information

Further products

- Centering Clamping Elements, with clamping balls, operation from the bottom

Drawing

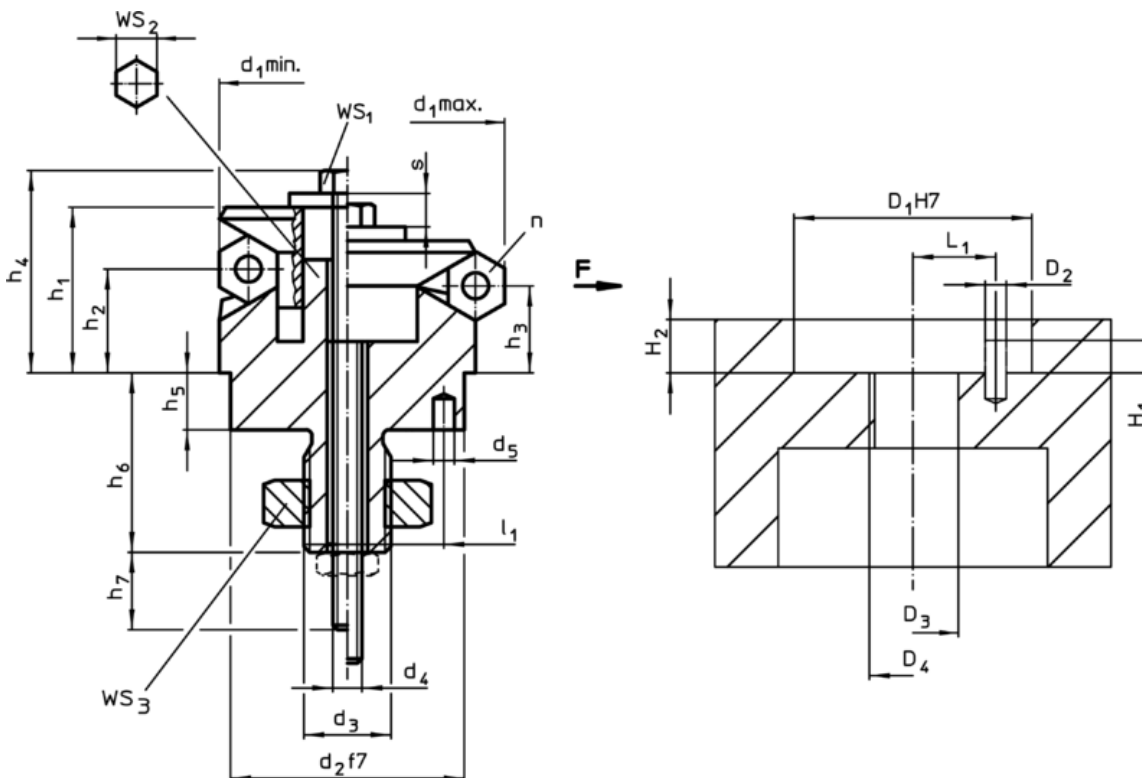

Order information

Dimensions													Number of segments n	Stroke s [mm]	WS			Clamping force F max. [kN]	Tightening torque max. [Nm]	Location hole					Art. No.
d ₁ min.	d ₁ max.	d ₂ f7	d ₃	d ₄	d ₅ +0,3	h ₁	h ₂	h ₃	h ₄ -2	h ₅	h ₆ +1	h ₇ ~			l ₁ ±0,1	WS ₁	WS ₂			WS ₃	D ₁	D ₂	D ₃	D ₄	
[mm]															[mm]					[mm]					
22,5	26,5	20	M10	M5	3	19,7	14,1	13	24,4	6	17,4	15	7	3	2,3	8	6	16	4,5	10	203	100	108,56	778	23340.0122

Application example

