

Centering Clamping Mandrels

23340.0112



Product Description

For clamping and centering of workpieces with internal bore.

Material

Body

- Steel, blackened

Clamping screw

- Case-hardened steel, case hardened

Assembly

The centering clamping mandrel can be machined to the required seating diameter (e.g. by turning/milling). It must be noticed that before machining the centering clamping mandrel, it will be expanded approx. 0.1 mm over the clamping diameter. To machine the mandrel, a nut will be provided.

More information

Notes

Special types on request.

Further products

- Centering Clamping Mandrels, with lateral handling

Drawing

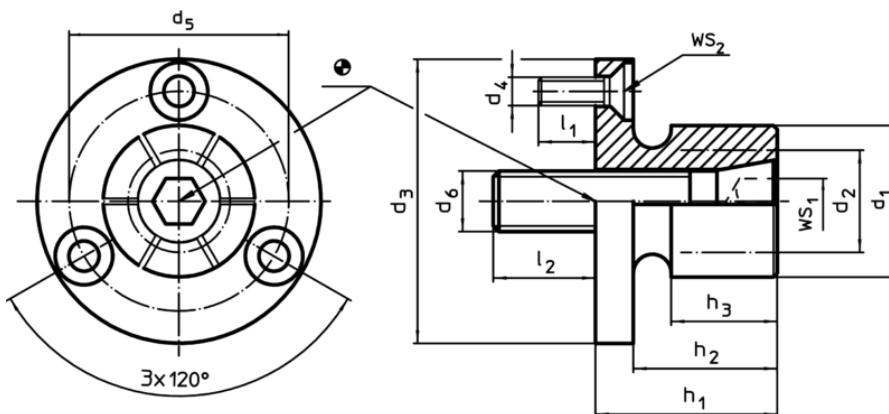

Order information

d ₁	d ₂ min.	d ₃ -0,05	d ₄	Dimensions								Number of segments	WS		Clamping force max. [kN]	Tightening torque max. [Nm]	Location hole H7 [mm]	Art. No.
				d ₅	d ₆	h ₁	h ₂	h ₃	l ₁	l ₂	WS ₁		WS ₂					
[mm]												[mm]						
35,3	25,4	56	M4	45,5	M12	31,8	25,4	20,6	7	21	6	10	2,5	15	105	56	322	23340.0112

Application example

