

Positioning Rings• For down-thrust clamp

23310.0351



Product Description

The positioning ring is an accessory to down-thrust clamps 23310.0050 - .0058 and 23310.0070. After aligning the clamp positioning rings are fitted on the spindle with the effect that repeated clamping is always exactly on the same point. Positioning ring is rotating by 360° on down-thrust clamps. After mounting the clamp can swing 110° to the left or right.

Material

- Steel, blackened

Assembly

Before mounting the positioning ring, pull-off top portion of down-thrust clamp.

Drawing

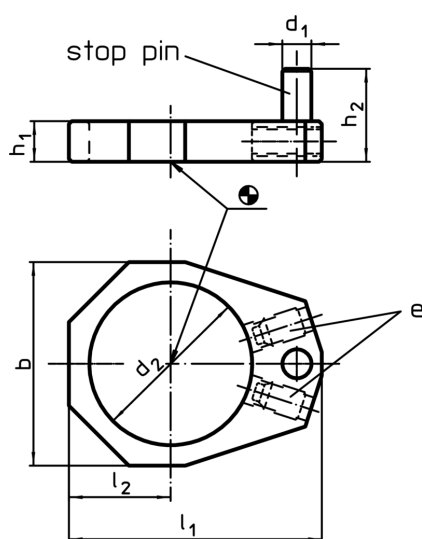

Order information

h ₁	h ₂	d ₁	Dimensions					e	For down-thrust clamp	[g]	Art. No.
			d ₂	l ₁	l ₂	b	[mm]				
15	40	10	62	93	39	78	22760.0104	23310.0070	340	23310.0351	

Application example

