

Down-Thrust Clamps · size 60

23310.0063



Product Description

Universal mechanical clamping element for fast and comfortable changing and clamping of workpieces by means of manually swivelling clamping claw.

Clamps provide the following advantages:

- rapid manual clamping by means of a threaded spindle or eccentric lever
- easy and rapid changing of workpieces by swinging away the clamping head
- compact construction, thus little space taken-up for clamping
- simple adaption even to extreme clamping heights, using height adjusting cylinders

Material

- Case-hardened steel, case-hardened, blackened and ground

Assembly

Down-thrust clamps can be fastened in two different ways:

1. with a nut for T-slots (DIN 508)
2. with a set screw directly in the mounting plate e.g. of a fixture

The cylinder has to rest on the entire surface. The clamping height h_1 must not be exceeded.

More information

References

The clamping height can be increased by using height adjusting cylinders EH 23310. and disks EH 1107., EH 1108. and EH 1617. It can be reduced by using clamping inserts.

Further products

- Height Adjusting Cylinders
- Spacers
- Wrenches
- Spacers

Drawing

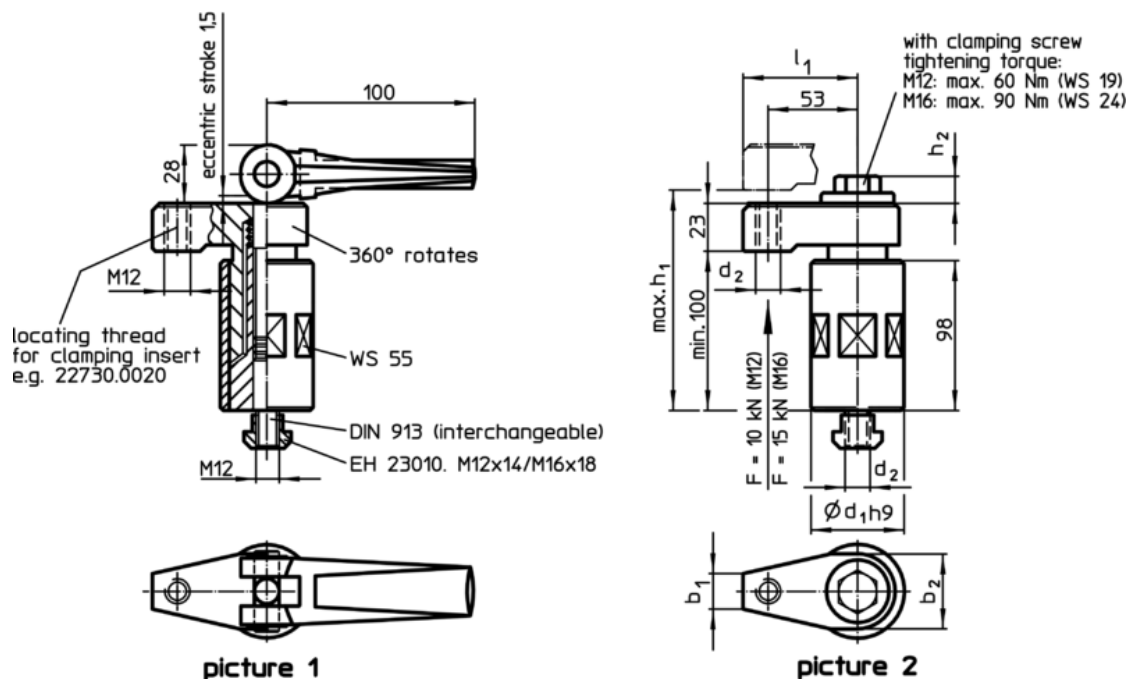

Order information

d ₁ h9	h ₁ max.	d ₂	Dimensions				[g]	Art. No.
			l ₁	h ₂	b ₁	b ₂		
[mm]								
with clamping screw – picture 2								
60	135	M16	69	16	24	53	2939	23310.0063

Application example

