

Double Edge Clamps

23251.0008



Product Description

Inserting the socket head screw moves the two clamping chucks outwards and presses the workpiece against a stop.

Material

Body

- Aluminium

Taper

- Case-hardened steel, blackened

Screw

- Steel

Assembly

Can be mounted in a threaded hole or with T-nuts for horizontal or vertical multiple clamping.

More information

Accessories

T-Nuts EH 23010. have to be purchased separately.

Further products

- Nuts for T-slots, DIN 508

Drawing

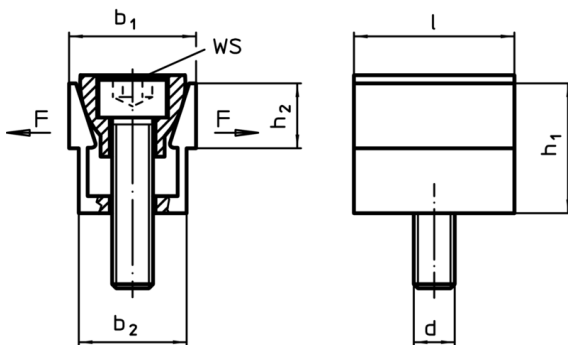

Order information

b ₁	b ₁ max. spread	b ₂	Dimensions				d	WS	Clamping force max.	Tightening torque max.	[g]	Art. No.
			h ₁	h ₂	l	[mm]						
24,8	26,9	20,8	25,9	12,7	31,7	M8	6	8,9	14,5	85	23251.0008	

Application example

