

Interchangeable Jaws for vices, with pull-down effect 23231.0033

Product Description



Material

Body

- Heat-treated steel, hardened

Roller

- Cold worked steel, hardened

Assembly

The base support (picture 1) is fixtured at the adaptor of the clamping vice with the standardly delivered screws. The interchangeable jaws - held by 2 permanent magnets - can be inserted and exchanged with a manual handle.

Assembly-/Disassembly instruction:

1. Pull the jaw upwards with the manual handle until the alignment pin strikes against the slot.
2. Twist the jaw sideways and remove.
3. New jaw can be inserted.

More information

Notes

The delivery includes tightening screws.

Drawing

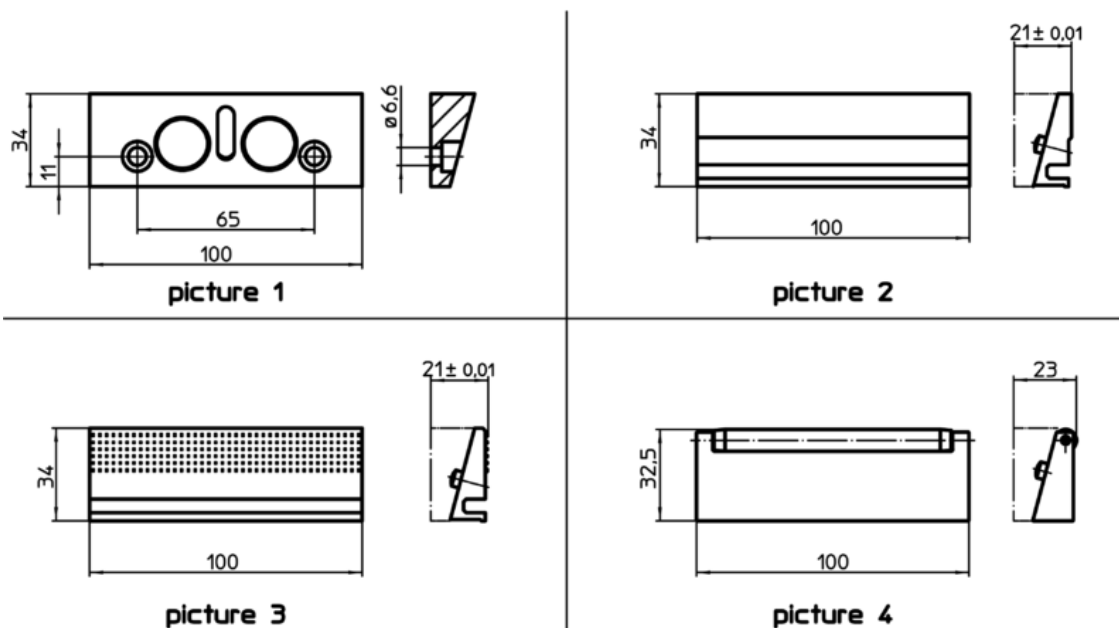

Order information

Nominal dimension [mm]	 [g]	Art. No.
interchangeable jaw with roller (body: head-treated steel, hardened / roller: cold worked steel, hardened – picture 4)		
100	270	23231.0033

Application example

