

Down-Hold Clamps· without clamping lever, with support

23210.0561



Product Description

By tightening the ball-ended thrust screw the workpiece is simultaneously pressed towards the stops and fixture plate. The favourable leverage enables high horizontal clamping forces. When using T-nuts EH 23010. / EH 23020. (DIN 508) they can also be applied to other slot sizes.

Material

- Steel, case-hardened, blackened, ground

More information

References

The integrated support is equipped with a location thread to fit for example screwed rest buttons EH 22690., self-aligning pads EH 22730. / EH 22740.

Further products

- Nuts for T-slots, DIN 508
- Nuts for T-slots, extended

Drawing

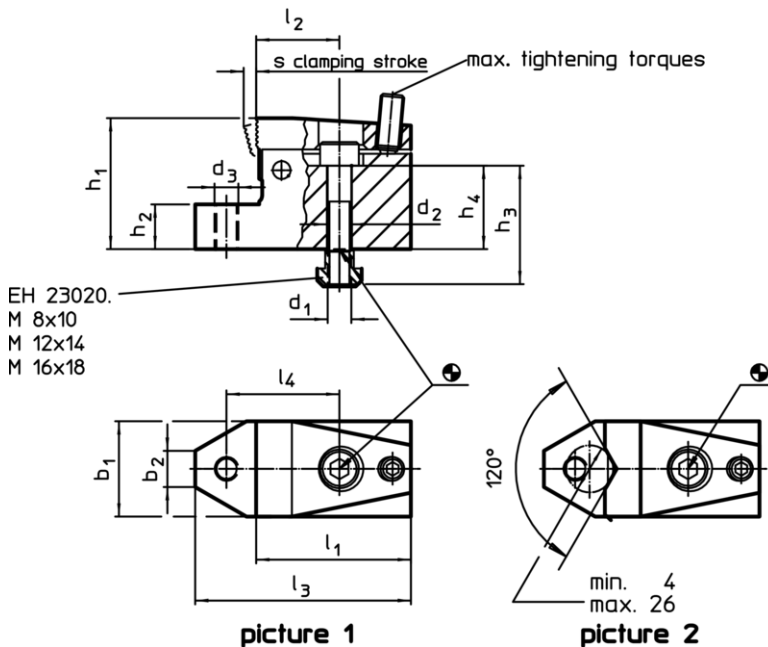

Order information

T-slot size	Dimensions														Clamping force horizontal max. [kN]	Tightening torque max. [Nm]	[g]	Art. No.		
	d ₁	d ₂	d ₃	b ₁	b ₂	h ₁	h ₂ ±0,01	h ₃ ~	h ₄ ~	l ₁	l ₂	l ₃	l ₄	s						
[mm]							[mm]													
with flat clamping jaw – picture 1																				
14	M12	13	M12	48	16	53	15	45	27	72	40	100	55	4	15	9	1342	23210.0561		

Application example

