

Down-Hold Clamps · without clamping lever

23210.0542

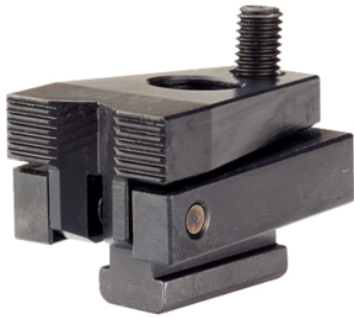

Product Description

By tightening the ball-ended thrust screw the workpiece is simultaneously pressed towards the stops and fixture plate. The favourable leverage enables high horizontal clamping forces. When using T-nuts EH 23010. / EH 23020. (DIN 508) they can also be applied to other slot sizes.

Material

- Steel, case-hardened, blackened, ground

More information

Further products

- Nuts for T-slots, DIN 508
- Nuts for T-slots, extended

Drawing

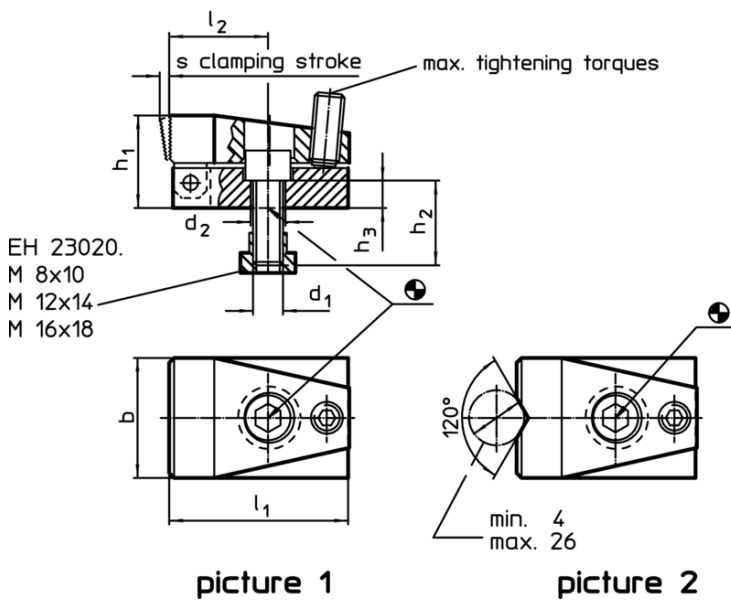

Order information

T-slot size	Dimensions									Clamping force horizontal max. [kN]	Tightening torque max. [Nm]	[g]	Art. No.
	d ₁	d ₂	b	h ₁	h ₂	h ₃	l ₁	l ₂	s				
[mm]	[mm]												
with V-clamping jaw – picture 2													
18	M16	16,5	68	47	35	13	86	41	7	21,5	20	1730	23210.0542

Application example

