

Down-Hold Clamps with cranked clamping lever

23210.0105



Product Description

The quick-acting clamping element simultaneously presses the workpieces towards both, the stops and fixture plate. The low profile construction enables the entire surface to be machined. In conjunction with cylindrical stops EH 23280., a special fixture can be replaced.

Material

- Steel, case-hardened, blackened

More information

Further products

- Stops, cylindrical

Drawing

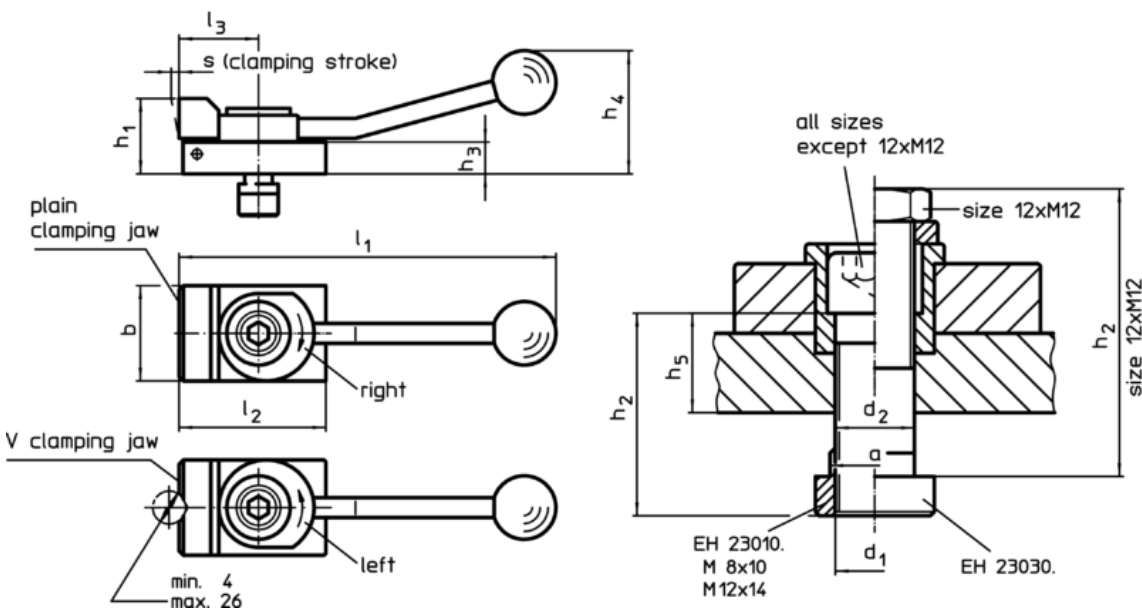

Order information

T-slot size	Dimensions													Clamping force horizontal max. [kN]	[g]	Art. No.
	d ₁	a	b	d ₂	h ₁	h ₂	h ₃	h ₄	h ₅	l ₁	l ₂	l ₃	s			
[mm]	[mm]															
with flat clamping jaw, clamping to the left																
10	M8	9,6	32	8,4	20	30	8	40	12,6	132	50	32	3	3,5	262	23210.0105

Application example

