

Locating Bushings• for positioning clamping pins, for screw fit

23111.0884

Product Description

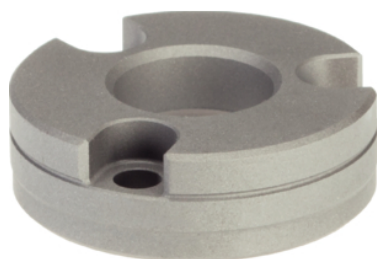

Material

- Stainless steel 1.4112, hardened

Assembly

The screw fit locating bushings for positioning clamping pins are inserted in the machine table or in the base plate and are screwed on. Supplied with mounting screws.

Drawing

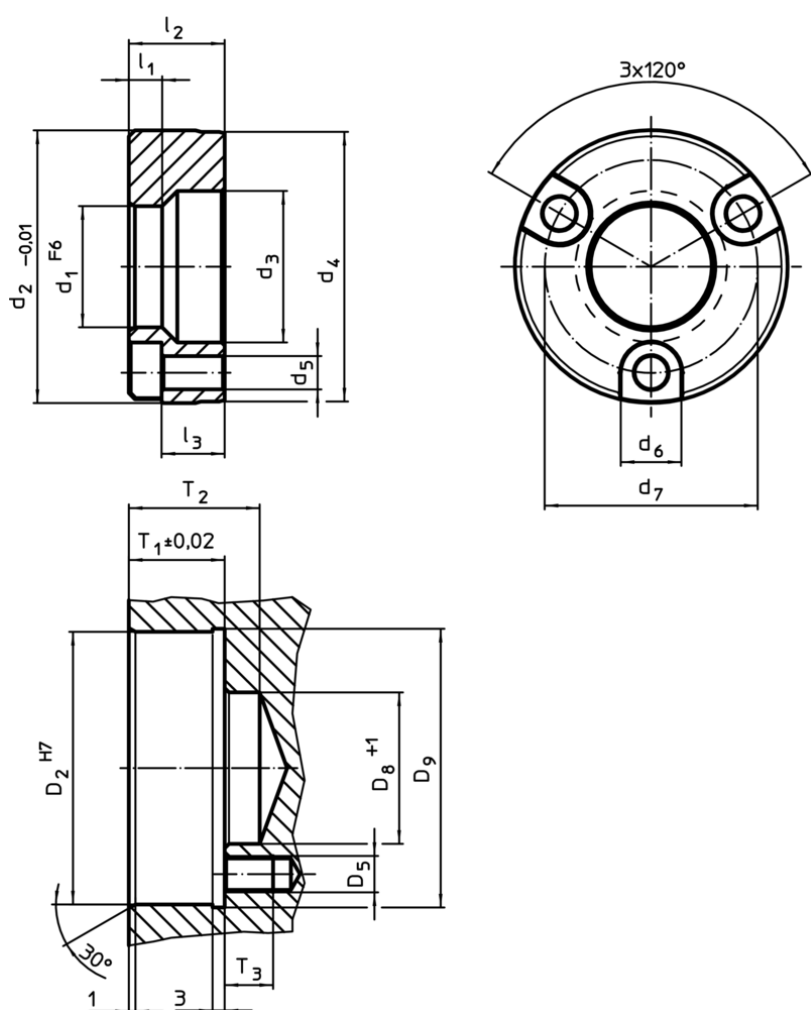

Order information

Dimensions										Location hole							[g]	Art. No.
d ₁	d ₂	d ₃	d ₄	d ₅	d ₆	d ₇	l ₁	l ₂	l ₃	D ₂	D ₅	D ₈	D ₉	T ₁	T ₂	T ₃		
F6	-0,01								~	H7		+1		±0,02				
[mm]										[mm]								
Stainless steel																		
20	44,99	25	44,5	5,5	10	35	5,25	15,82	10	45	M5	25	46,5	16,21	22	12	130	23111.0884

Application example

