

Bushings for positioning clamping pins

23111.0814



Product Description

Material

- Stainless steel 1.4112, hardened

Assembly

Two centering bushes and two floating bushes are to be mounted into the plate to be clamped in order to guarantee an optimal repeatability.

Characteristic

The floating bush has a groove that serves as a differentiation mark.

Drawing

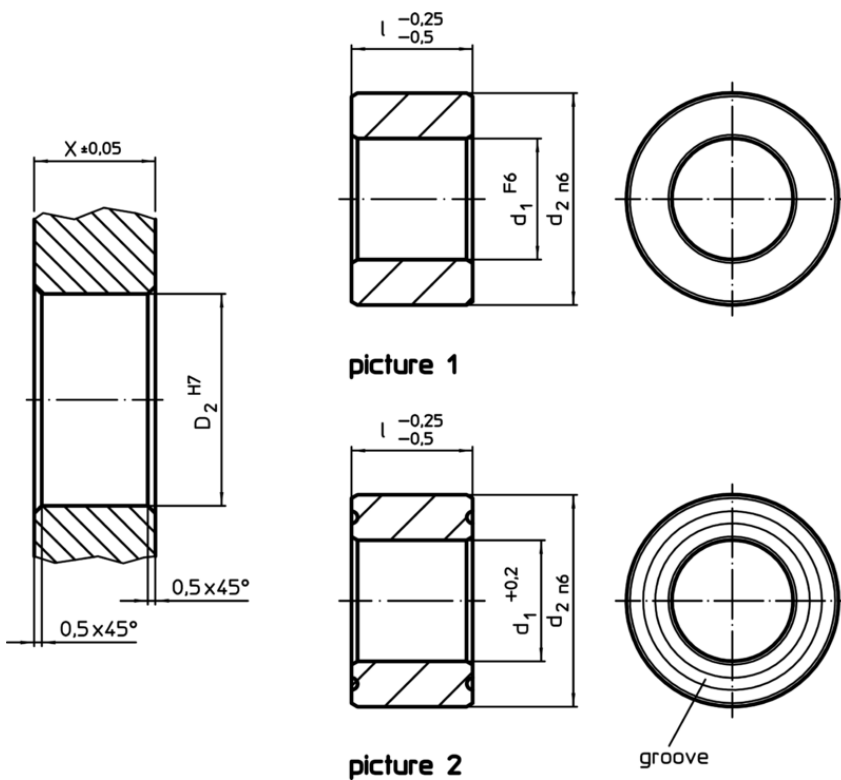

Order information

d ₁	Dimensions l	d ₂	Location hole		D ₂	[g]	Art. No.
			X	[mm]			
F6	-0,25 -0,5 [mm]	n6	±0,05		H7		
central – picture 1, Stainless steel							
30	20	45	20		45	140	23111.0814

Application example

