

Locating Bushings• for positioning clamping pins, for screw fit

23111.0788

Product Description



Material

- Case-hardened steel, case-hardened, blackened

Assembly

The screw fit locating bushings for positioning clamping pins are inserted in the machine table or in the base plate and are screwed on. Supplied with mounting screws.

Drawing

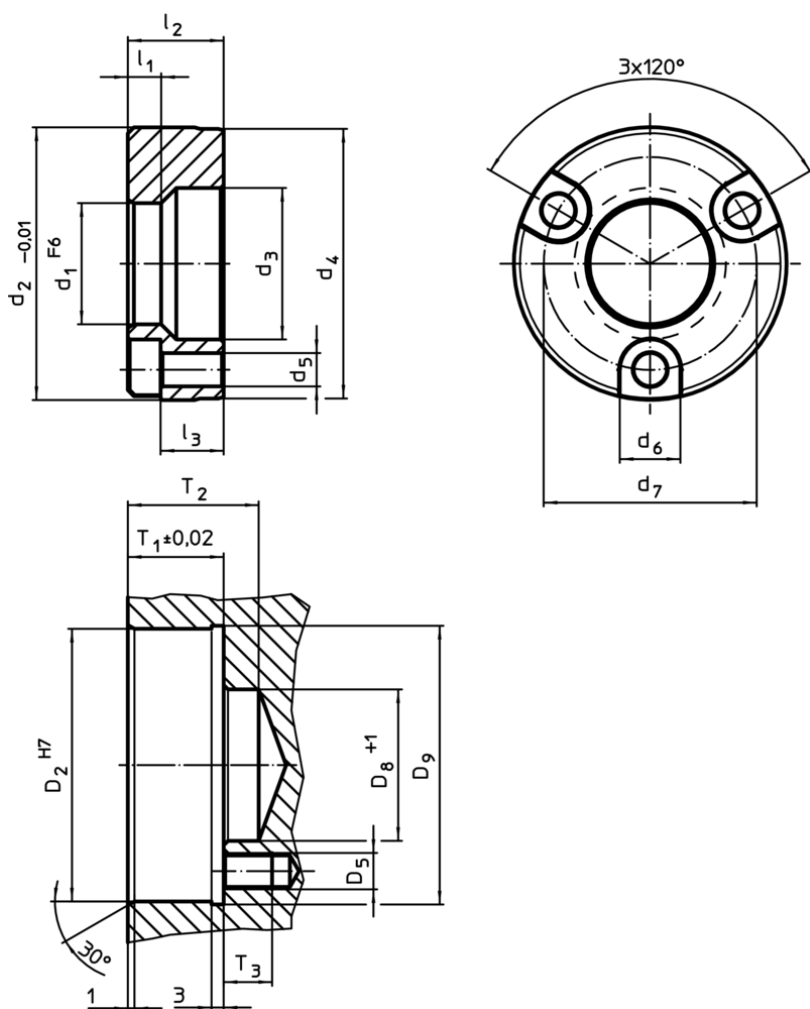

Order information

Dimensions										Location hole						[g]	Art. No.	
d ₁	d ₂	d ₃	d ₄	d ₅	d ₆	d ₇	l ₁	l ₂	l ₃	D ₂	D ₅	D ₈	D ₉	T ₁	T ₂			T ₃
F6	-0,01								~	H7		+1		±0,02				
[mm]										[mm]								
Case-hardened steel																		
30	59,99	37	59,5	6,6	11	48	5,25	21,77	15	60	M6	37	61,5	22,15	28	14	195	23111.0788

Application example

