

## Locating Bushings• for positioning clamping pins, for screw fit

23111.0782

### Product Description



#### Material

- Case-hardened steel, case-hardened, blackened

#### Assembly

The screw fit locating bushings for positioning clamping pins are inserted in the machine table or in the base plate and are screwed on. Supplied with mounting screws.

### Drawing

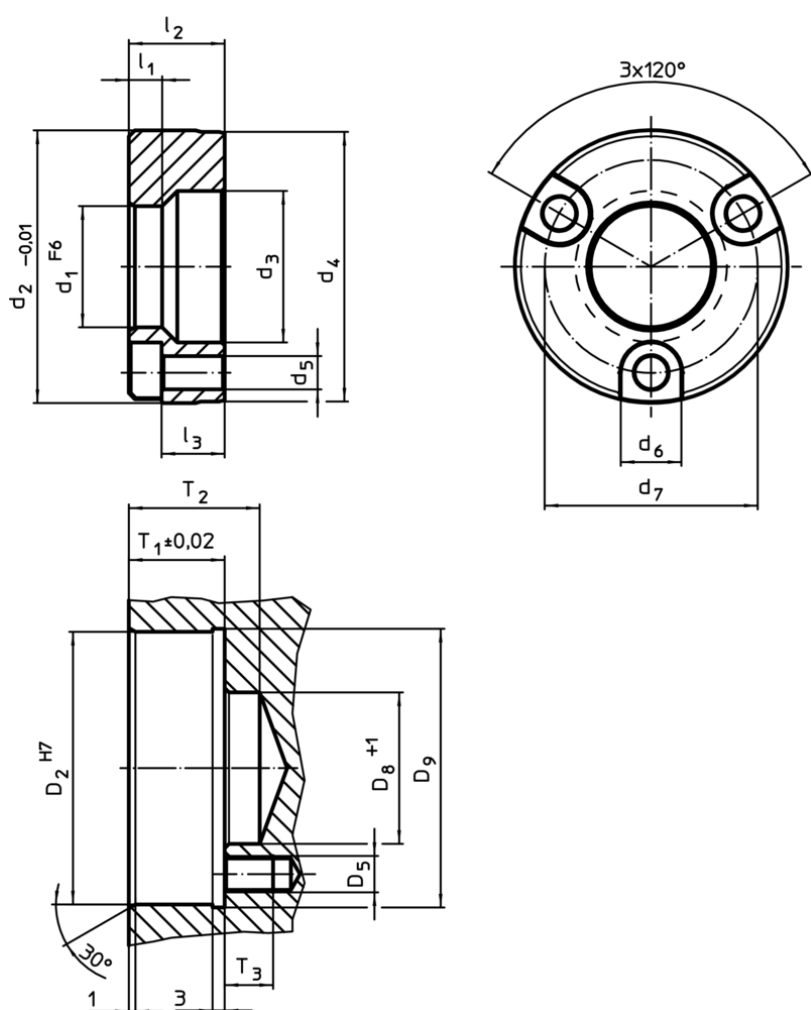

### Order information

Dimensions										Location hole							[g]	Art. No.
d <sub>1</sub>	d <sub>2</sub>	d <sub>3</sub>	d <sub>4</sub>	d <sub>5</sub>	d <sub>6</sub>	d <sub>7</sub>	l <sub>1</sub>	l <sub>2</sub>	l <sub>3</sub>	D <sub>2</sub>	D <sub>5</sub>	D <sub>8</sub>	D <sub>9</sub>	T <sub>1</sub>	T <sub>2</sub>	T <sub>3</sub>		
F6	-0,01								~	H7		+1		±0,02				
[mm]										[mm]								
Case-hardened steel																		
16	36,99	20	36,5	4,5	8	29	5,25	11,56	7	37	M4	20	38,5	11,91	22	12	70	23111.0782

Application example

