

Positioning Clamping Pins

23111.0032



Product Description

The positioning clamping pin allows fast clamping, fastening, adjusting, changing and securing of workpieces, plates, fixture systems etc.

Material

- Heat-treated steel, tempered, blackened

Operation

By tightening the clamping screws, the positioning clamping pin is centered and clamped with four balls in the locating bush. The clamping screw can be operated manually via a removable handle (Art.-Nr. 23111.0900/.0902) or via an hex. key.

More information

Accessories

Suitable bushings are available.

Further products

- Manual Handles, for positioning clamping pins
- Bushings, for positioning clamping pins
- Locating Bushings, for positioning clamping pins, for press fit
- Locating Bushings, for positioning clamping pins, for screw fit

Drawing

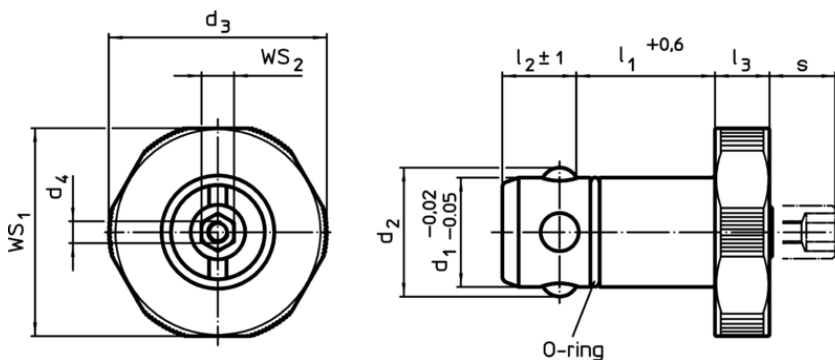

Order information

Dimensions		For base plates $\pm 0,05$	WS_1	WS_2	Holding force		Art. No.						
d_1	l_1							d_2	d_3	d_4	l_2	l_3	s
-0,02 -0,05	+0,6		[mm]	[mm]	[kN]	[g]							
Heat-treated steel													
30	30	34,6	55	M4	18,6	10	9	25	53	10	10	400	23111.0032

Application example

