

Positioning Clamping Pins

23111.0022



Product Description

The positioning clamping pin allows fast clamping, fastening, adjusting, changing and securing of workpieces, plates, fixture systems etc.

Material

- Heat-treated steel, tempered, blackened

Operation

By tightening the clamping screws, the positioning clamping pin is centered and clamped with four balls in the locating bush. The clamping screw can be operated manually via a removable handle (Art.-Nr. 23111.0900/.0902) or via an hex. key.

More information

Accessories

Suitable bushings are available.

Further products

- Manual Handles, for positioning clamping pins
- Bushings, for positioning clamping pins
- Locating Bushings, for positioning clamping pins, for press fit
- Locating Bushings, for positioning clamping pins, for screw fit

Drawing

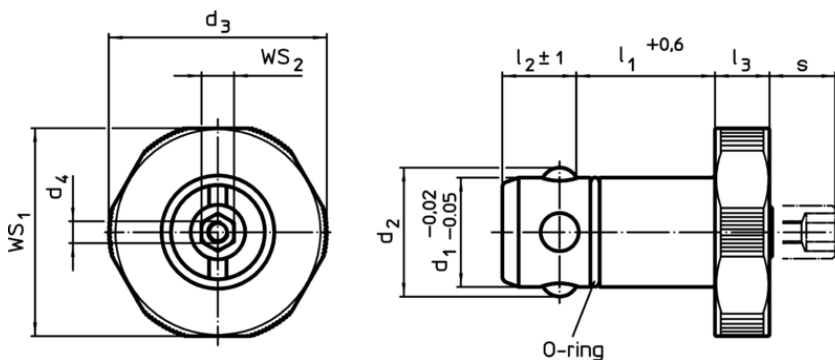

Order information

Dimensions									For base plates ±0,05	WS ₁	WS ₂	Holding force		Art. No.
d ₁	l ₁	d ₂	d ₃	d ₄	l ₂	l ₃	s	[mm]						
-0,02 -0,05	+0,6				±1		~							
Heat-treated steel														
20	30	23,6	40	M4	13,6	10	9	25	38	6	6	185	23111.0022	

Application example

