

## Spherical Washers / Conical Seats • similar to DIN 6319, stainless steel

23050.0466

### Product Description



#### Material

- Conical seat**
- Stainless steel 1.4305

#### Assembly

Conical seats form D are to be used only for plain, closed round areas. For larger holes only use form G!

#### More information

#### Further products

- Spherical Washers / Conical Seats, DIN 6319
- Fixture Nuts, DIN 6330 (height 1,5 d)

### Drawing

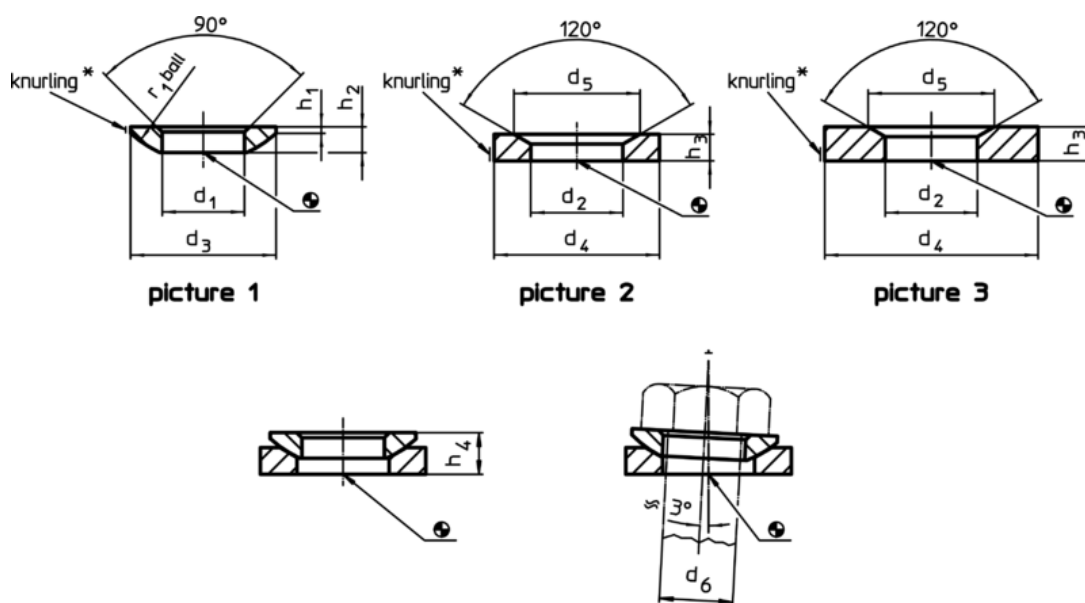

\* Knurling = material identification for stainless steel A4 type

### Order information

d <sub>2</sub> H13	Dimensions			For pin d <sub>6</sub> [mm]	For screws d <sub>6</sub> [mm]	Load capacity for static load max. [kN]	Torque for screwed connections <sup>1)</sup> max. [Nm]	[g]	Art. No.
	d <sub>4</sub> [mm]	d <sub>5</sub> [mm]	h <sub>3</sub> [mm]						
conical seats from stainless steel, form G – picture 3, Stainless steel 1.4305									
7,1	17	11	4	6	M6	6	6	5,8	23050.0466

<sup>1)</sup> Torques of screws A2-70 to be seen as very rough values only having information character; eventual pre-loads to be considered, coefficient of friction  $\mu_{total}$  0,12.

Application example

