

Spherical Washers / Conical Seats• similar to DIN 6319, stainless steel

23050.0324

Product Description



Material

Spherical washer
• Stainless steel 1.4305

Assembly

Conical seats form D are to be used only for plain, closed round areas.
For larger holes only use form G!

More information

Further products

- Spherical Washers / Conical Seats, DIN 6319
- Fixture Nuts, DIN 6330 (height 1,5 d)

Drawing

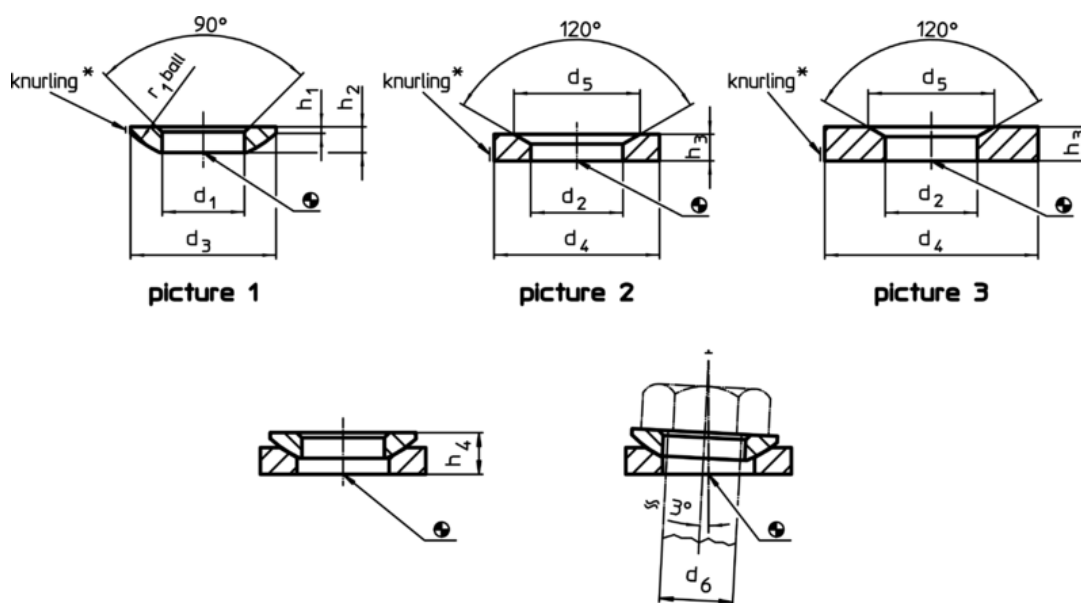

* Knurling = material identification for stainless steel A4 type

Order information

d ₁	d ₃	h ₁	h ₂	Dimensions		r ₁	For pin d ₆	For screws d ₆	Load capacity for static load max.	Torque for screwed connections ¹⁾ max.	[g]	Art. No.
				with conical seat form D	with conical seat form G							
[mm]												
H13												
spherical washers from stainless steel, form C – picture 1, Stainless steel 1.4305												
25	44	2,4	8,2	14,9	15,4	32	24	M24	105	455	46	23050.0324

¹⁾ Torques of screws A2-70 to be seen as very rough values only having information character; eventual pre-loads to be considered, coefficient of friction μ_{total} 0,12.

Application example

