

Spherical Washers / Conical Seats• DIN 6319

23050.0112

Product Description



Material

Conical seat

- Case-hardened steel, case-hardened, manganese phosphate treated

Assembly

Conical seats form D are to be used only for plain, closed round areas.
For larger holes only use form G!

More information

Further products

- Spherical Washers / Conical Seats, similar to DIN 6319, stainless steel
- Fixture Nuts, DIN 6330 (height 1,5 d)

Drawing

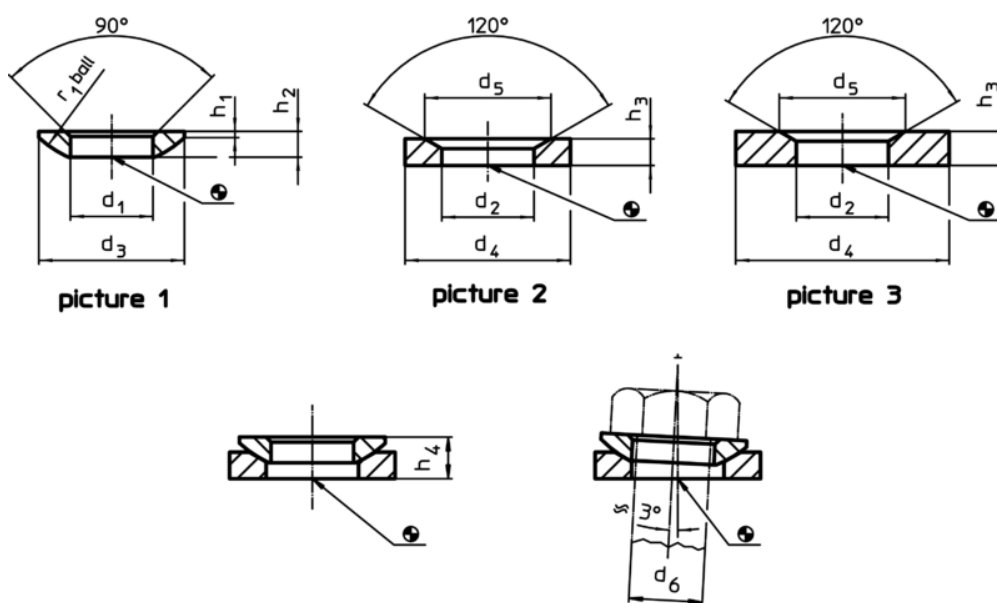

Order information

d ₂ H13	Dimensions			For pin d ₆ [mm]	For screws d ₆ [mm]	Load capacity for static load max. [kN]	Torque for screwed connections ¹⁾ max. [Nm]	 [g]	Art. No.
	d ₄	d ₅	h ₃						
	[mm]	[mm]	[mm]						
conical seats from case-hardened steel, form D – picture 2									
14,2	24	20	5	12	M12	38	82	10	23050.0112

¹⁾ Torques of screws 8.8, eventual pre-loads to be considered, coefficient of friction μ_{total} 0,14.

Application example

