

Spherical Washers / Conical Seats• DIN 6319

23050.0064

Product Description



Material

Spherical washer

- Case-hardened steel, case-hardened, manganese phosphate treated

Assembly

Conical seats form D are to be used only for plain, closed round areas.
For larger holes only use form G!

More information

Further products

- Spherical Washers / Conical Seats, similar to DIN 6319, stainless steel
- Fixture Nuts, DIN 6330 (height 1,5 d)

Drawing

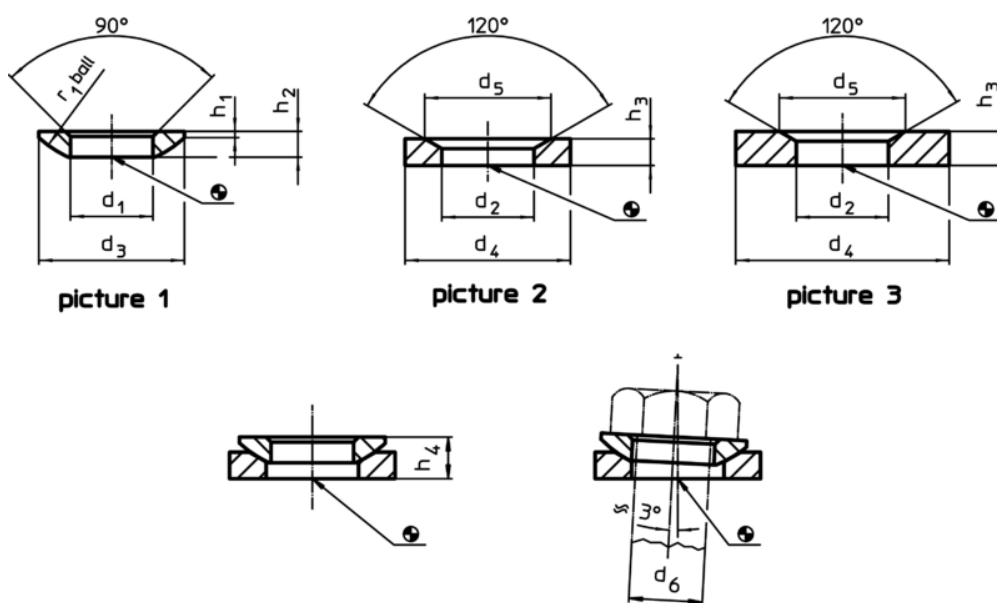

Order information

d ₁ H13	d ₃	Dimensions				r ₁	For pin d ₆	For screws d ₆	Load capacity for static load ¹⁾ max.	Torque for screwed connections ^{1) 2)} max.	[g]	Art. No. ³⁾
		h ₁	h ₂	h ₄ with conical seat form D ~	[mm]							
spherical washers from case-hardened steel, form C – picture 1												
66	120	12	27	46,6	93	64	M64	1269	14762	1220	23050.0064	

¹⁾ Figures theoretically determined

²⁾ Torques of screws 8.8, eventual pre-loads to be considered, coefficient of friction μ_{total} 0,14.

³⁾ DIN standards do not include these dimensions.

Application example

