

## Spherical Washers / Conical Seats• DIN 6319

23050.0056

### Product Description



#### Material

##### Spherical washer

- Case-hardened steel, case-hardened, manganese phosphate treated

#### Assembly

Conical seats form D are to be used only for plain, closed round areas.  
For larger holes only use form G!

#### More information

#### Further products

- Spherical Washers / Conical Seats, similar to DIN 6319, stainless steel
- Fixture Nuts, DIN 6330 (height 1,5 d)

### Drawing

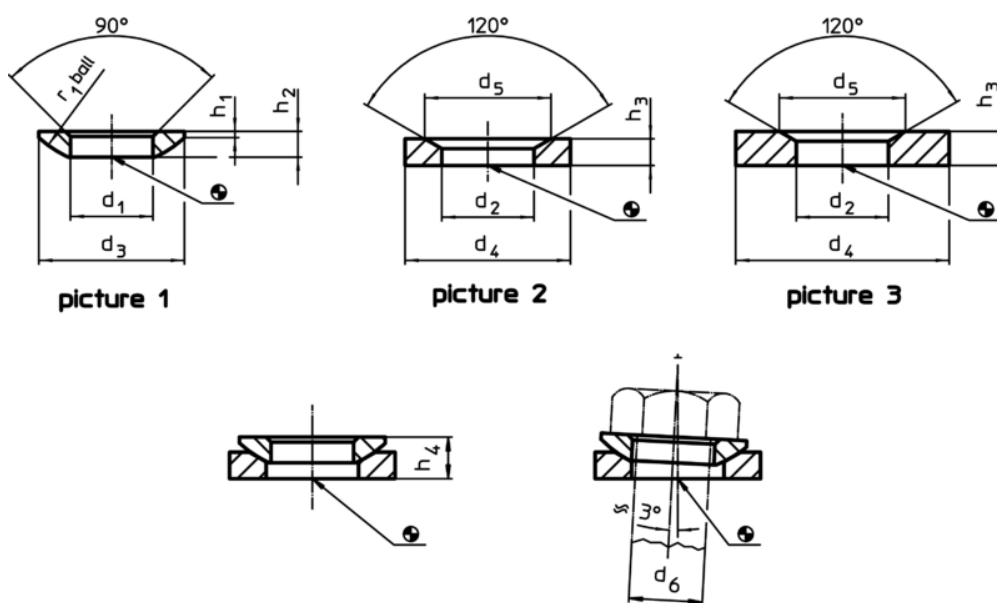

### Order information

d <sub>1</sub> H13	d <sub>3</sub>	Dimensions				r <sub>1</sub>	For pin d <sub>6</sub>	For screws d <sub>6</sub>	Load capacity for static load <sup>1)</sup> max.	Torque for screwed connections <sup>1) 2)</sup> max.	Art. No. <sup>3)</sup>
		h <sub>1</sub>	h <sub>2</sub>	h <sub>4</sub> with conical seat form D ~	[mm]						
<b>spherical washers from case-hardened steel, form C – picture 1</b>											
58	103	9,8	23	39,3	79	56	M56	960	9793	760	23050.0056

<sup>1)</sup> Figures theoretically determined

<sup>2)</sup> Torques of screws 8.8, eventual pre-loads to be considered, coefficient of friction  $\mu_{total}$  0,14.

<sup>3)</sup> DIN standards do not include these dimensions.

Application example

