

Spherical Washers / Conical Seats • DIN 6319

23050.0010

Product Description



Material

Spherical washer

- Case-hardened steel, case-hardened, manganese phosphate treated

Assembly

Conical seats form D are to be used only for plain, closed round areas.
For larger holes only use form G!

More information

Further products

- Spherical Washers / Conical Seats, similar to DIN 6319, stainless steel
- Fixture Nuts, DIN 6330 (height 1,5 d)

Drawing

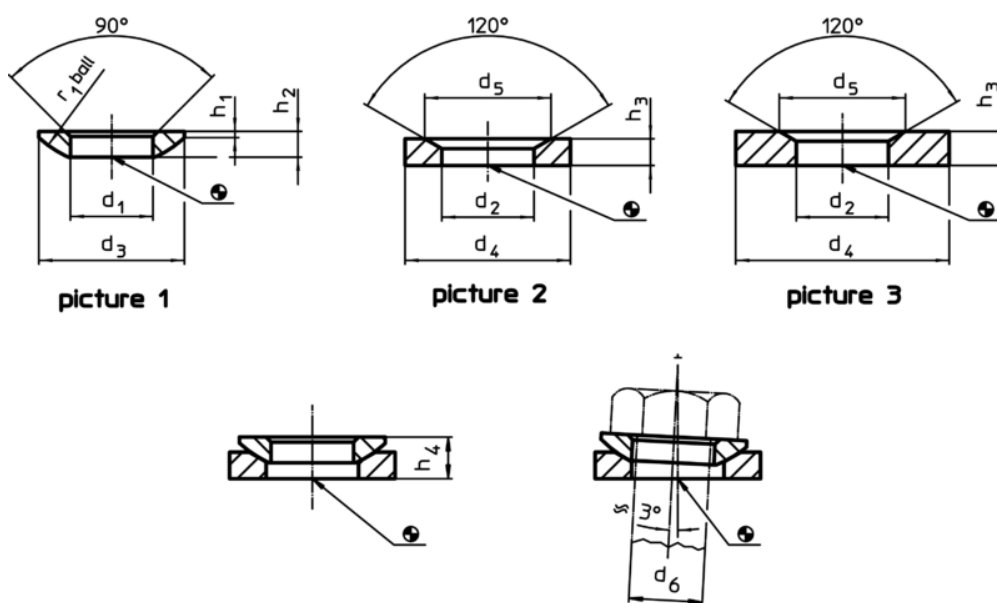

Order information

d ₁ H13	d ₃	h ₁	Dimensions		r ₁	For pin d ₆ [mm]	For screws d ₆ [mm]	Load capacity for static load max. [kN]	Torque for screwed connections ¹⁾ max. [Nm]	[g]	Art. No.	
			h ₂ [mm]	h ₄ with conical seat form D ~ with conical seat form G ~ [mm]								
spherical washers from case-hardened steel, form C – picture 1												
10,5	21	0,8	4	6,5	7,3	15	10	M10	26	46	5,3	23050.0010

¹⁾ Torques of screws 8.8, eventual pre-loads to be considered, coefficient of friction μ_{total} 0,14.

Application example

