

Ball Casters with mounting elements

22750.0112

Product Description



Material

Cap

- Steel, zinc-plated by galvanization

Housing

- Steel, zinc-plated by galvanization

Ball

- Ball-bearing steel

Assembly

Mounting is carried-out by means of spring-loaded claws allowing big tolerances in the location hole.

The ball casters can easily be mounted and disassembled from their functional side. Due to the inclined cap form, the assembly mandrel EH 22750. should be used.

Drawing

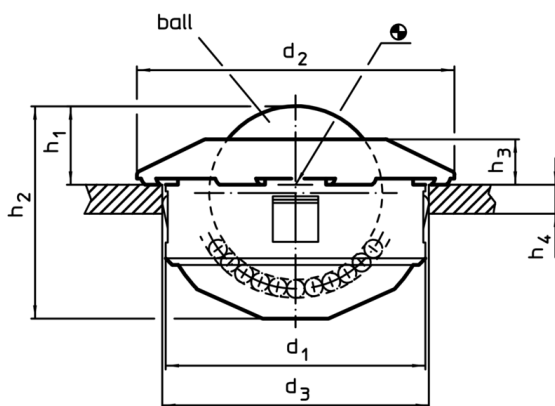

Order information

d ₁ -0,16	Ball Ø	d ₂	Dimensions h ₁ ±0,3 [mm]	h ₂	h ₃	h ₄ min.	Location hole D ₁ [mm]	Carrying figure C [N]	[g]	Art. No.
ball from ball-bearing steel										
45	30	55	13,8	37,5	8	2,5	45	2500	292	22750.0112

Accessories

Suitable for ball caster [mm]	[g]	Art. No.
assembly tool		
24	451	22750.0144
36	480	22750.0148
45	503	22750.0152

Application example

