

## Ball Casters with sheet steel housing

22750.0032



### Product Description

Ball casters are module for transport systems, conveyances, to working and packing facilities. For example, parts can be easily moved, turned and controlled. As from  $d_1 = 36$  fitted with an oil drenched felt seal to protect against dirt.

### Material

#### Cap

- Steel, zinc-plated by galvanization

#### Housing

- Steel, zinc-plated by galvanization

#### Ball

- Stainless steel

### More information

#### Further products

- Tolerance Rings

### Drawing

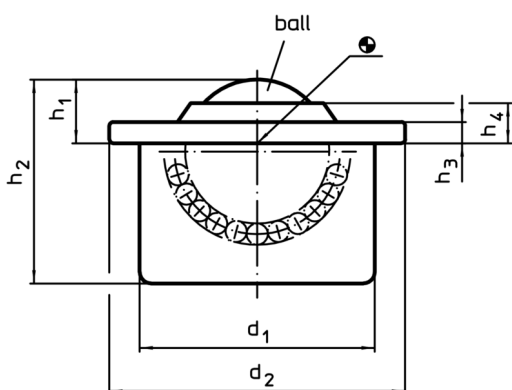

### Order information

$d_1$ $\pm 0,08$	Ball $\emptyset$	$d_2$	Dimensions				Carrying figure C [N]	Location hole $D_1^{1)}$ +0,05 [mm]	[g]	Art. No.
			$h_1$ $\pm 0,3$ [mm]	$h_2$	$h_3$	$h_4$				
all parts zinc-plated, ball from stainless steel										
45	30	55	13,8	37,5	3,7	7,9	1900	44,85	273	22750.0032

<sup>1)</sup> Reference value for 2 mm sheet steel/ 5 mm aluminium (force fit)

Application example

