

Ball Casters with sheet steel housing

22750.0008



Product Description

Ball casters are module for transport systems, conveyances, to working and packing facilities. For example, parts can be easily moved, turned and controlled. As from $d_1 = 36$ fitted with an oil drenched felt seal to protect against dirt.

Material

Cap

- Steel, zinc-plated by galvanization

Housing

- Steel, zinc-plated by galvanization

Ball

- Ball-bearing steel

More information

Further products

- Tolerance Rings

Drawing

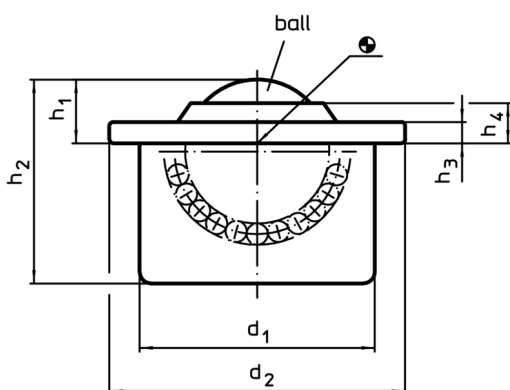

Order information

d_1 $\pm 0,08$	Ball \emptyset	d_2	Dimensions				Carrying figure C [N]	Location hole $D_1^{1)}$ +0,05 [mm]	 [g]	Art. No.
			h_1 $\pm 0,2$ [mm]	h_2	h_3	h_4				
cap and housing zinc-plated										
36	22	45	9,8	29,5	2,9	5,7	1300	35,9	134	22750.0008

¹⁾ Reference value for 2 mm sheet steel/ 5 mm aluminium (force fit)

Application example

