

## Ball Casters with sheet steel housing

22750.0004



### Product Description

Ball casters are module for transport systems, conveyances, to working and packing facilities. For example, parts can be easily moved, turned and controlled. As from  $d_1 = 36$  fitted with an oil drenched felt seal to protect against dirt.

### Material

#### Cap

- Steel, zinc-plated by galvanization

#### Housing

- Steel, zinc-plated by galvanization

#### Ball

- Ball-bearing steel

### More information

#### Further products

- Tolerance Rings

### Drawing

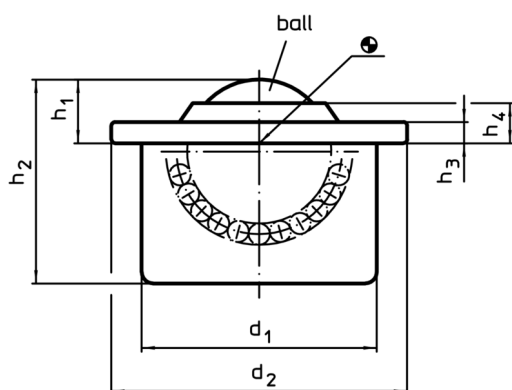

### Order information

d <sub>1</sub> ±0,065	Ball Ø	d <sub>2</sub>	Dimensions				Carrying figure C [N]	Location hole D <sub>1</sub> <sup>1)</sup> +0,05 [mm]	[g]	Art. No. <sup>2)</sup>
			h <sub>1</sub> ±0,2 [mm]	h <sub>2</sub>	h <sub>3</sub>	h <sub>4</sub>				
<b>cap and housing zinc-plated</b>										
24	15	31	9,5	21,5	2,5	6,1	500	23,95	40	22750.0004

<sup>1)</sup> Reference value for 2 mm sheet steel/ 5 mm aluminium (force fit)

<sup>2)</sup> without felt seal

Application example

