

Seating Pins• ribbed or pointed

22680.0123



Product Description

For workpieces showing a rough surface. Pointed type especially suitable for cast parts.

Material

Insert

- Hard metal, pointed

Body

- Heat-treated steel, tempered, blackened

Drawing

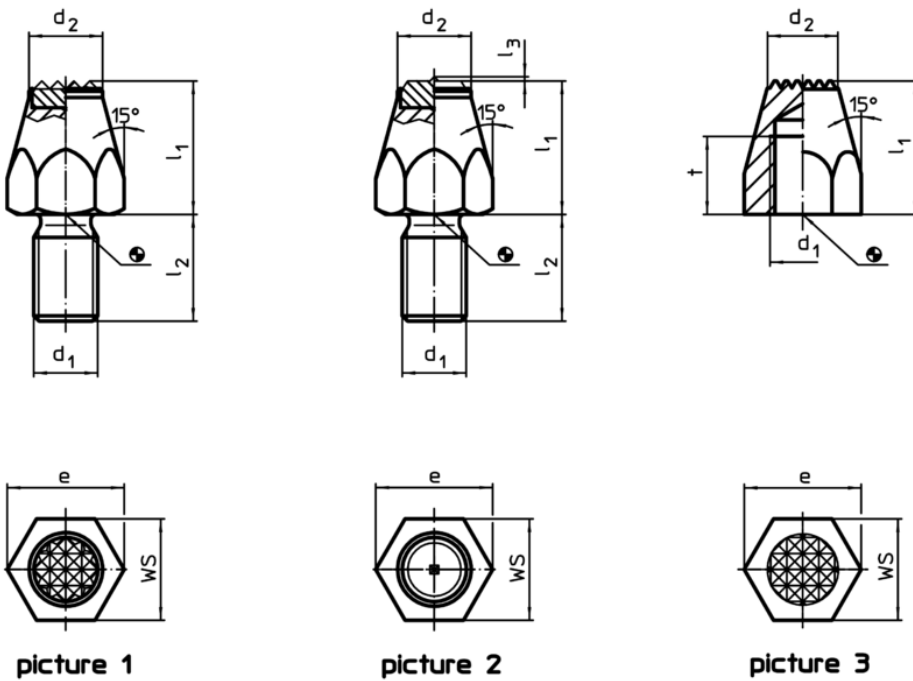

Order information

Dimensions						WS	Tightening torque max.	g	Art. No.
l_1	d_1	l_2	l_3	d_2	e				
[mm]						[mm]	[Nm]	[g]	
with hard metal insert, pointed, and threaded shank – picture 2									
25	M12	20	0,8	13,8	21,9	19	60	65	22680.0123

Application example

