

Hard Metal Inserts

22620.0631



Product Description

Basic element to be mounted into clamping devices, clamping jaws, clamping arms, claw feed systems and so forth.

For an abrasion-proof transmission of high holding forces, e. g. on cast or forged pieces.

Material

Insert

- Hard metal, pointed

Assembly

Mounting can take place by either soldering, glueing or pressing in. The three positioning tabs guarantee exact centering and when being glued or pressed in, article is secured against rotating. Depending on the individual element choose a mounting diameter between d_1 and d_2 .

Drawing

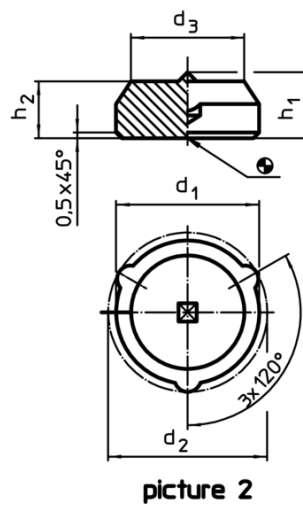
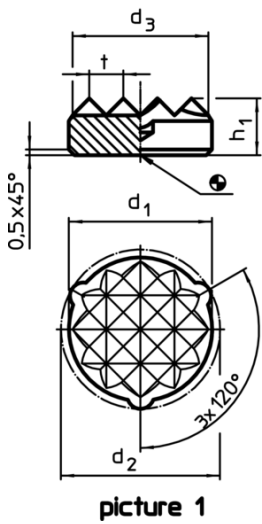

Order information

Dimensions					[g]	Art. No.
d_1 $\pm 0,1$	d_2 $\pm 0,2$	d_3 ~ [mm]	h_1	h_2		
pointed – picture 2						
11,3	12,1	9,3	5,8	5	6,7	22620.0631

Application example

