

## Hard Metal Inserts

22620.0611



### Product Description

Basic element to be mounted into clamping devices, clamping jaws, clamping arms, claw feed systems and so forth.

For an abrasion-proof transmission of high holding forces, e. g. on cast or forged pieces.

### Material

#### Insert

- Hard metal, ribbed

### Assembly

Mounting can take place by either soldering, glueing or pressing in. The three positioning tabs guarantee exact centering and when being glued or pressed in, article is secured against rotating. Depending on the individual element choose a mounting diameter between  $d_1$  and  $d_2$ .

### Drawing

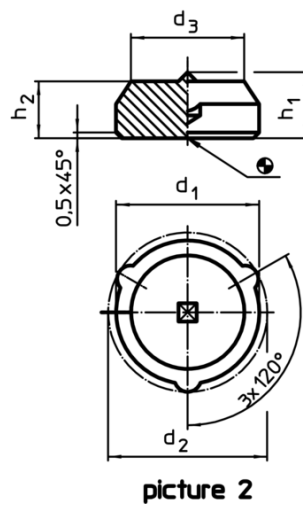
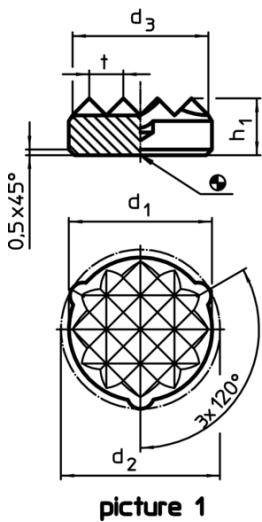

### Order information

$d_1$ $\pm 0,1$	$d_2$ $\pm 0,2$	Dimensions			$h_1$	$t$	[g]	Art. No.
		$d_3$ ~	[mm]					
ribbed – picture 1								
11,3	12,1	10,6	5	2	6,1	22620.0611		

Application example

