

## Hard Metal Inserts• for locating hole

22620.0228



### Product Description

Basic element to be mounted into clamping devices, clamping jaws, clamping arms, claw feed systems and so forth.

Zero play transmission of high holding forces, e.g. on cast or forged pieces.

### Material

**Insert**  
• Hard metal, pointed

**Body**  
• Heat-treated steel, tempered, phosphated

### Assembly

Assembly via a locating hole, the insert can be fastened by means of a screw.

### Drawing

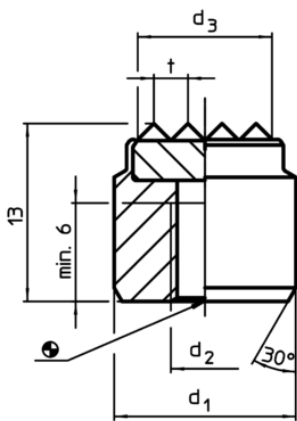

picture 1

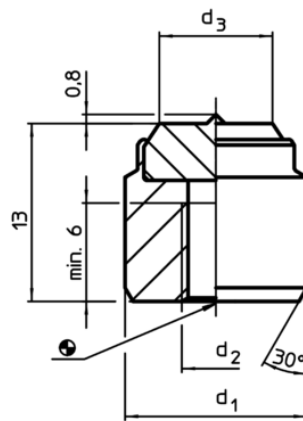

picture 2

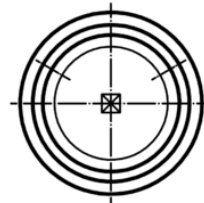
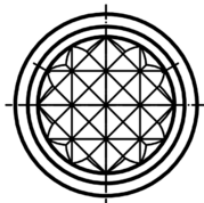

### Order information

d <sub>1</sub> n6	Dimensions		Location hole H7	[g]	Art. No.
	d <sub>2</sub> [mm]	d <sub>3</sub> ~			
pointed – picture 2					
10	M5	6,3	10	7,8	22620.0228

Application example

