

Hard Metal Inserts• for locating hole

22620.0211



Product Description

Basic element to be mounted into clamping devices, clamping jaws, clamping arms, claw feed systems and so forth.

Zero play transmission of high holding forces, e.g. on cast or forged pieces.

Material

Insert
• Hard metal, ribbed

Body

• Heat-treated steel, tempered, phosphated

Assembly

Assembly via a locating hole, the insert can be fastened by means of a screw.

Drawing

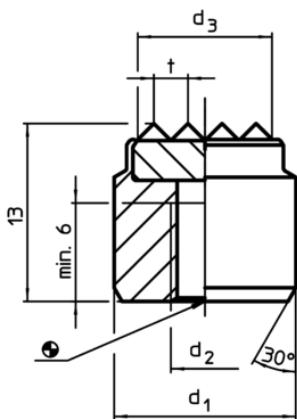

picture 1

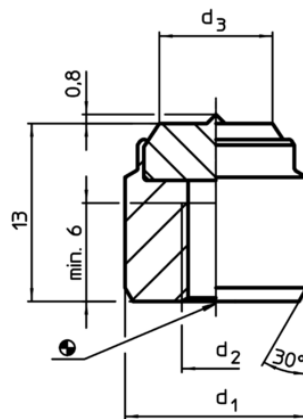

picture 2

Order information

d ₁ n6	d ₂	Dimensions			Location hole H7	[g]	Art. No.
		[mm]	d ₃ ~	t			
ribbed – picture 1							
14	M6		10,6	2	14	15	22620.0211

Application example

