

Mounting Pads

22590.0208



Product Description

Mounting pads can be used as foot or thrust pad. Not parallel bearing surfaces up to 15° degrees can be compensated.

Material

Ball element

- Stainless steel 1.4305

Pad

- Stainless steel 1.4305

More information

Notes

For the versions $d_1 = M10$ and $M12$ the lock nut conforms to DIN 934.

Drawing

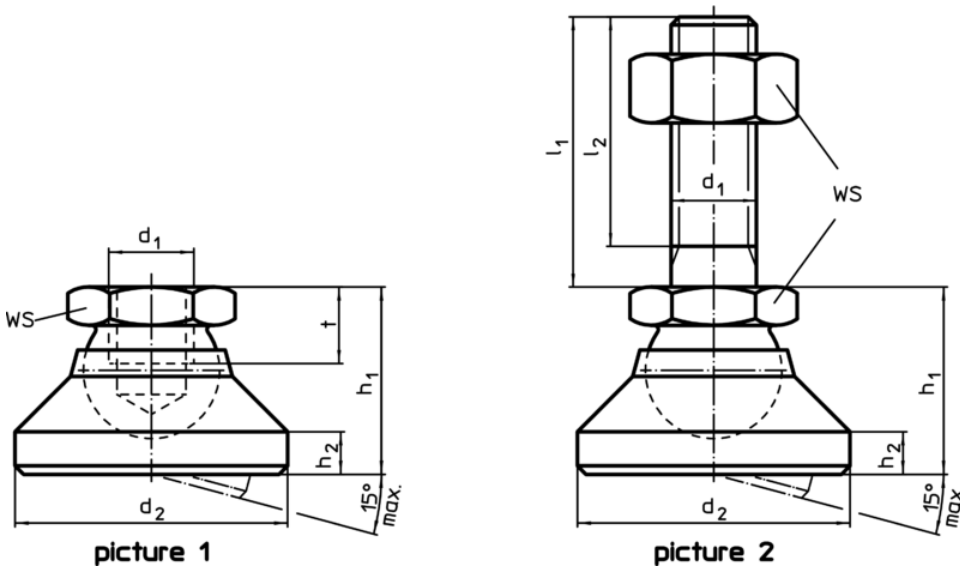

Order information

Dimensions					WS	Load capacity for static load max.	max.		Art. No.
d_1	d_2	h_1	h_2	t	[mm]	[kN]	[°C]	[g]	
pad and ball element – picture 1, Stainless steel									
M8	25	18	4	7	13	14	250	33	22590.0208

Application example

