

## Mounting Pads

22590.0020



### Product Description

Mounting pads can be used as foot or thrust pad. Not parallel bearing surfaces up to 15° degrees can be compensated.

### Material

#### Ball element

- Heat-treated steel, tempered, blackened

#### Pad

- Heat-treated steel, blackened

### More information

#### Notes

For the versions  $d_1 = M10$  and  $M12$  the lock nut conforms to DIN 934.

### Drawing

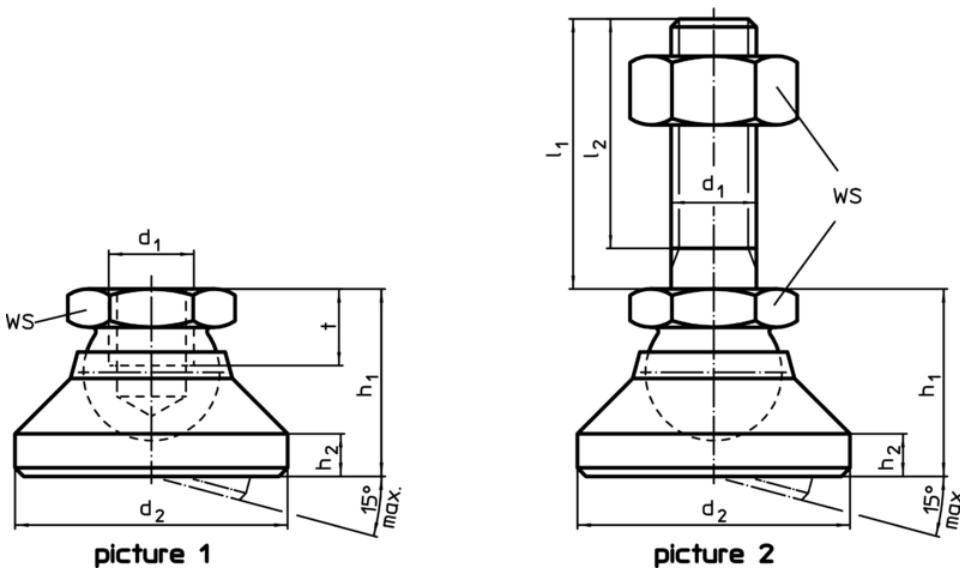

### Order information

Dimensions					WS	Load capacity for static load max.	max. [°C]	[g]	Art. No.
d <sub>1</sub>	d <sub>2</sub>	h <sub>1</sub>	h <sub>2</sub>	t					
pad and ball element – picture 1, Heat-treated steel									
M20	60	42	8	17	30	55	250	413	22590.0020

Application example

