

Mounting Pads

22590.0010



Product Description

Mounting pads can be used as foot or thrust pad. Not parallel bearing surfaces up to 15° degrees can be compensated.

Material

Ball element

- Heat-treated steel, tempered, blackened

Pad

- Heat-treated steel, blackened

More information

Notes

For the versions $d_1 = M10$ and $M12$ the lock nut conforms to DIN 934.

Drawing

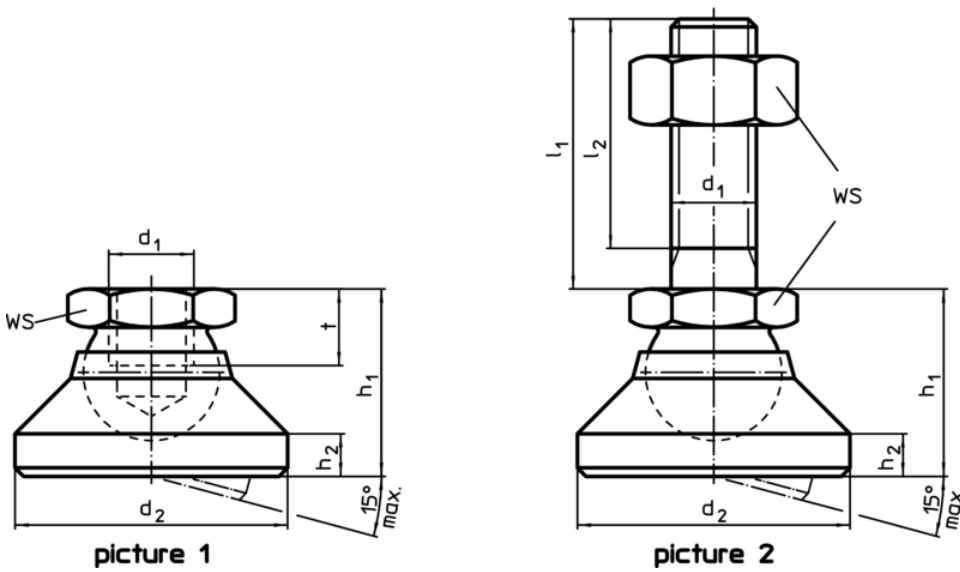

Order information

Dimensions					WS	Load capacity for static load max.	max.		Art. No.
d_1	d_2	h_1	h_2	t	[mm]	[kN]	[°C]	[g]	
[mm]					[mm]				
pad and ball element – picture 1, Heat-treated steel									
M10	32	22	5	9	17	20	250	66	22590.0010

Application example

