

Thrust Pads- DIN 6311 and low model
22560.0432

Product Description

Combinable with grub screws DIN 6332 with thrust point EH 22540.



Material

- Steel, case-hardened, blackened. Snap ring inlaid.

Assembly

The thrust pad is to be held the way the spring retainer lies in the recess with its open side at the bottom. The grub screw is inclined as far as possible in the direction of the open side of the ring and pressed in.

More information

Further products

- Grub Screws, DIN 6332 with thrust point

Drawing

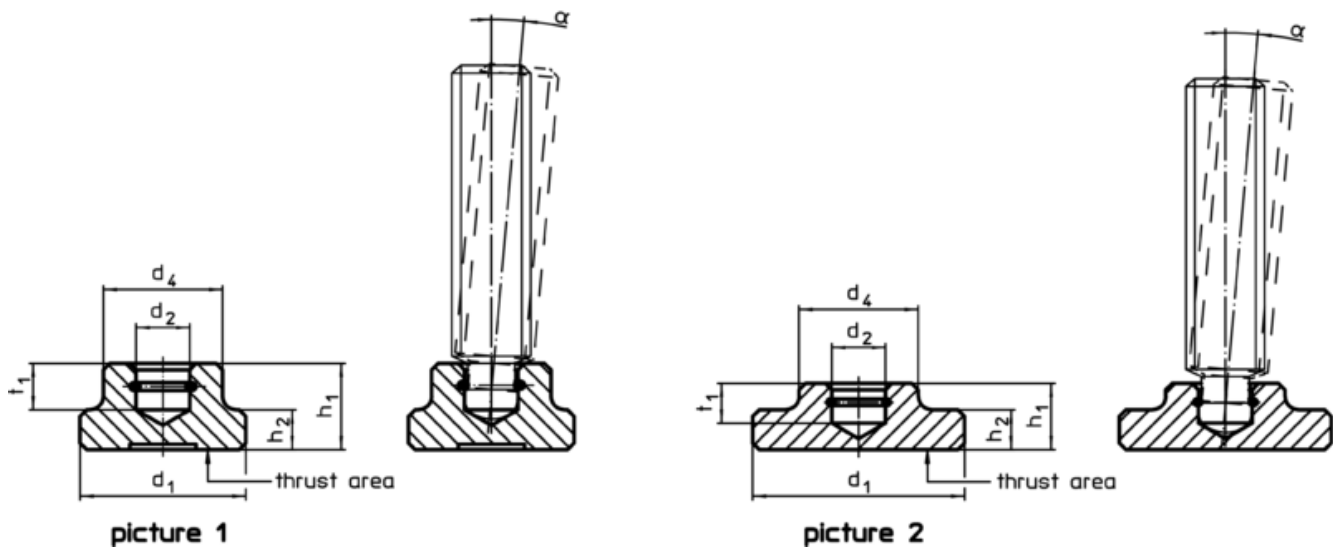

Order information

d ₁	d ₂ H12	Dimensions					For grub screws with thrust point DIN 6332 [mm]	α min.	 [g]	Art. No.
		d ₄	h ₁	h ₂	t ₁	[mm]				
low model with increased thrust area and spring retainer – picture 2										
32	8,1	18	10	6	6	M10/M12	3°	43	22560.0432	

Application example

