

Clamping Pins• self-locking, with span compensation

22360.0042



Product Description

Used for fixing and simultaneously tightly connecting thin walled plates. Clamping distance of 5 mm for clamping of sheets for welding work, for protection, coverings, to close doors etc. All versions are corrosion resistant. Version with ergonomic grip.

Material

Pin part

- Stainless steel 1.4305

Handle

- Thermoplastic PA 6, grey

Spring

- Stainless steel

Operation

The balls are unlocked by pressing the knob.

More information

Accessories

Can easily be fitted with retaining cable EH 22400.

Further products

- Locating Bushings, for ball lock pins and socket pins
- Locating Bushings, with flange, for ball lock pins and socket pins
- Retaining Cables

Drawing

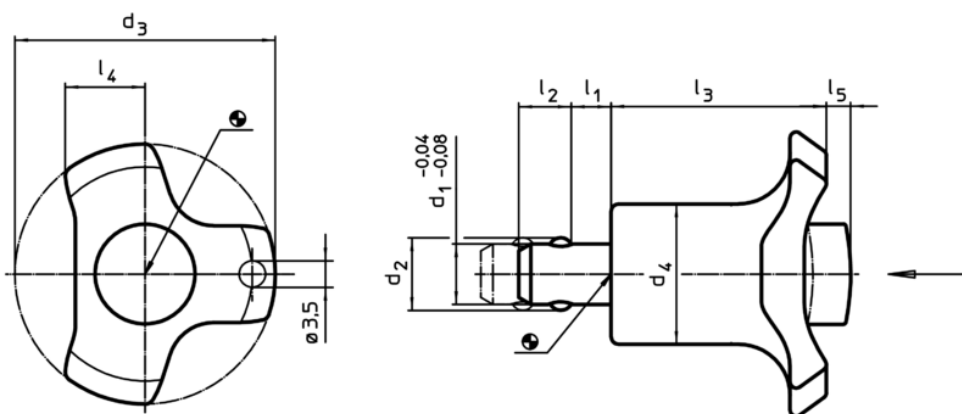

Order information

Dimensions									Location hole H11	Clamping force max.	min. max.		Art. No.	
d_1	l_1	d_2	d_3	d_4	l_2	l_3	l_4	l_5	[mm]	[N]	[°C]			[g]
-0,04 -0,08								Unclamped						
				[mm]					[mm]					
12	5 – 10	14	47	23	9,4	36	13,5	4	12	23	-30	80	54	22360.0042

Application example

