

Lifting Pins• self-locking, with handle

22351.0010



Product Description

The t-handled grip can be used to move or transport workpieces via hand, e.g. part finished components, workholding systems, speakers and other containers. Corrosion and weathering resistant, thus also suitable for outdoor application. Very solid, precipitation-hardened pin with an extreme load capacity.

Material

Pin part

- Stainless steel 1.4542, precipitation-hardened

Handle

- Aluminium, blue anodised

Press button

- Aluminium, blue anodised

Spring

- Stainless steel

Assembly

Simple H11 boreholes are sufficient. Each lifting pin contains an instruction manual with an EC Declaration of Conformity.

Operation

The balls are unlocked by pressing the knob.

More information

Further products

- Locating Bushings, for lifting pins
- Locating Bushings, plain, for lifting pins
- Locating bushing with seal, plain, for lifting pins

Drawing

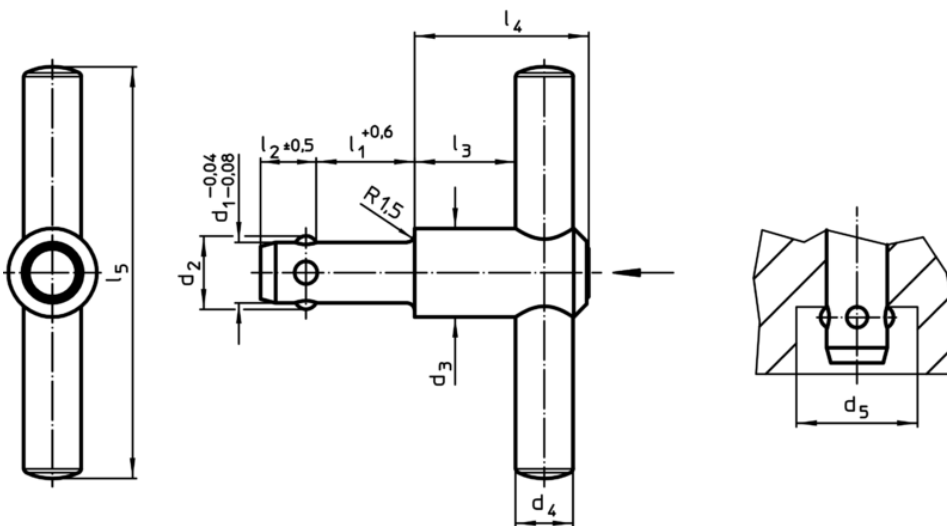

Order information

Dimensions										Carrying force	Location hole	Temperature	Weight	Art. No.
d_1	l_1	d_2	d_3	d_4	d_5 min.	l_2	l_3	l_4	l_5	F_1	H11	max.	[g]	
[mm]										[N]	[mm]	[°C]		
8,3	35	9,65	21,5	14	10,05	8,75	18,7	36	100	500	8,3	250	142	22351.0010

Application example

