

Locating Bushings• for lifting pins

22350.0926



Product Description

Locating bushings are used for quick and safe locating of lifting pins EH 22350. Corrosion and abrasion resistant.

Material

- Stainless steel 1.4542, precipitation-hardened

Assembly

Ensure safe tolerances and consistent function. Easily incorporable into different materials. Can be used in thin-walled pieces. Can be mounted in blind holes. In the case of thin-walled pieces, assembly is carried out using a lock nut.

Drawing

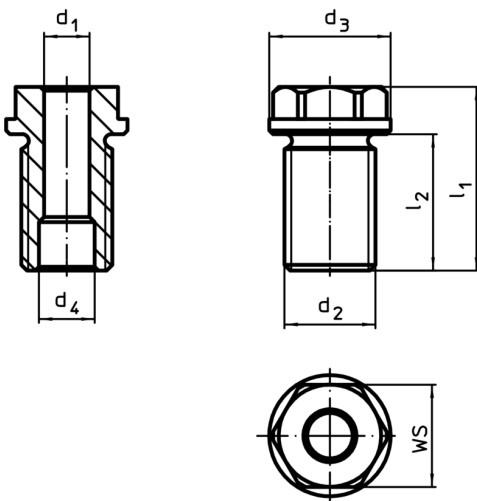

Order information

Dimensions		For nominal length l [mm]	Dimensions				WS [mm]	Tightening torque max. [Nm]	x ¹⁾ [mm]	Carrying force ¹⁾ [kN]			For lifting pin	Art. No.	
d ₁ H11 [mm]	d ₂ [mm]		d ₃ -0,2	d ₄ +0,3	l ₁	l ₂				F ₁	F ₂	F ₃			
12	M24	50	32	14,7	72,5	60	27	200	1,5	3,5	3,2	2,8	22350.0637 / .0737	164	22350.0926

¹⁾ for a 5-fold safety against breakage

Application example

