

## Clamping Catches

22260.0250



### Product Description

Clamping catches have a round running taper surface and enable fast and safe clamping and releasing with a relatively large adjustment range and high tensioning force. Due to the small gradient angle of the taper surface, the clamping catch is self-locking.

### Material

#### Body

- Steel, case-hardened, blackened

#### Screw

- Steel, nitrided

#### Gear lever handle

- Steel, ground, blackened

#### Ball knob

- Thermosetting plastic PF 31, black, DIN 319

### Assembly

Fix with screw bolt M 10 (SW 6). Ensure a tightening torque of max. 40 Nm.

### Operation

The screw bolt and the washer are adjustable. Once screwed in, the clamping catch can easily be turned to the desired position. For Art. No. 22260.0250 / .0251 and 22260.0450 / .0451, the serration helps to put the clamping lever to the preferred position.

### More information

### Notes

Left turn type can be supplied on request.

### Drawing

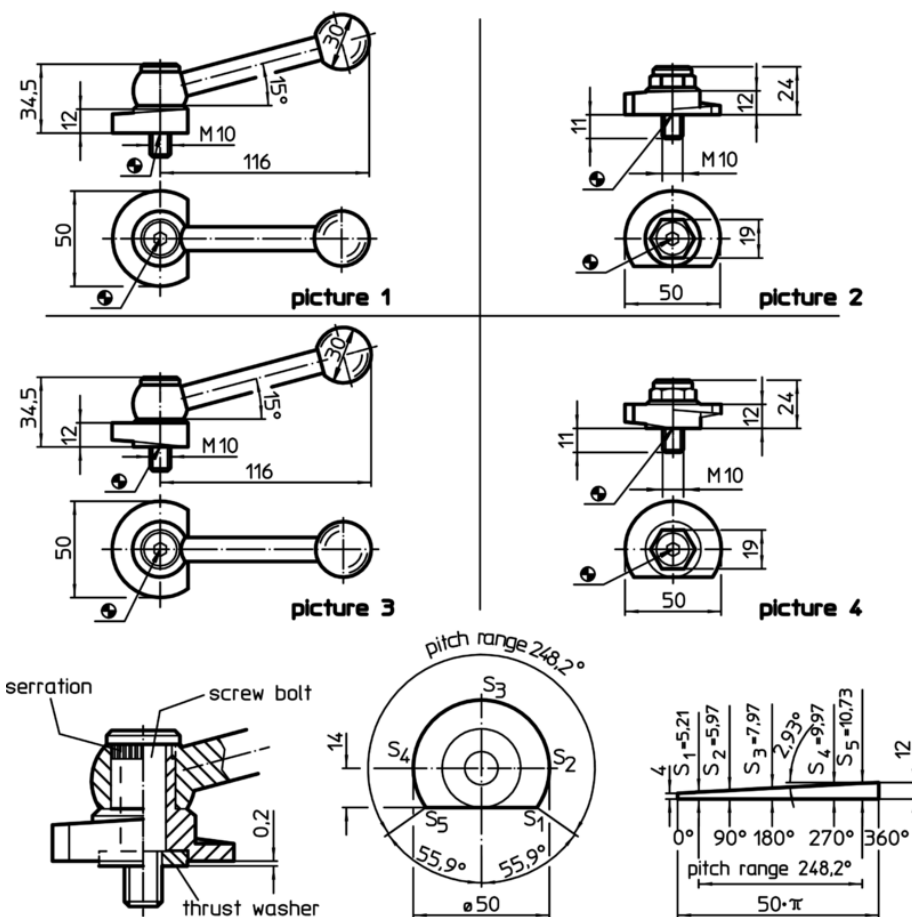

### Order information

Art. No.	
 [g] with adjustable clamping lever, pitch opposite to bearing surface – picture 1, Steel 304	22260.0250

Application example

