

Lateral Plungers with thread, with seal, with female thread

22150.1460



Product Description

To be used for positioning and applying pressure, e.g. during painting and sandblasting. Sealed against chips and dirt.

Material

Seal

- CR

Body

- Steel, zinc-plated

Threaded washer

- Steel, blackened

Spring

- Steel, zinc-plated by galvanization

Assembly

Formula for calculating the center distance for the mounting hole:

$$l_0 = z/2 + w + x,$$

l_0 = center distance,

y = workpiece height,

w = workpiece length,

x = stroke,

z = stop diameter

Calculation dimension x for workpieces: $x =$

$$d_2/2 - s$$

Lateral plungers are installed by screwing in by means of a mounting tool.

Characteristic

Heavy spring load = spring from steel, zinc-plated by galvanization

More information

Notes

Individual set screws can be screwed in the plate with threaded hole.

Drawing

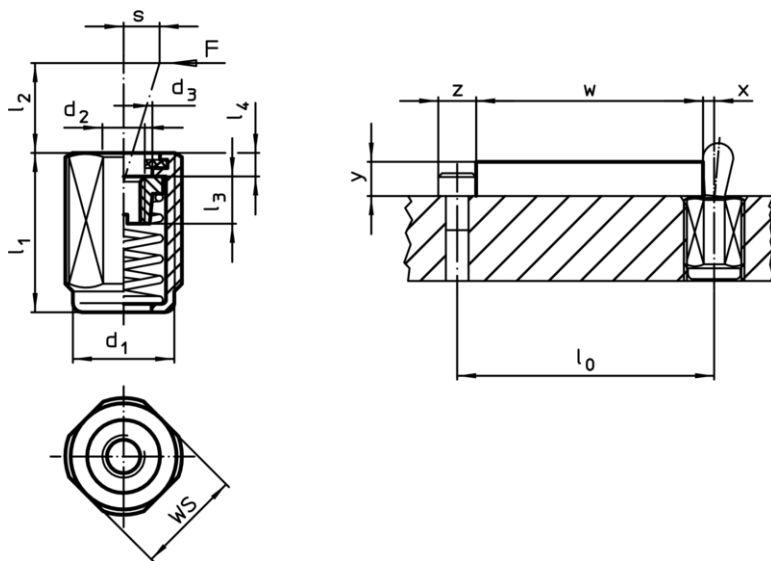

Order information

Dimensions		Spring load F max. ¹⁾ ~ [N]	d ₂	d ₃	Dimensions			Stroke s [mm]	WS [mm]	max. [°C]	[g]	Art. No.
d ₁	l ₁ -2				l ₂	l ₃	l ₄					
[mm]					[mm]							
heavy spring load												
M18 x 1,5	45	200	M6	10,1	11,5	7,5	2,3	3,2	16	110	32	22150.1460

¹⁾ statistical average value

Accessories

	Dimensions d_1 [mm]	 [g]	Art. No.
assembly tool	M18 x 1,5	137	22150.0822

Application example

