

Lateral Plungers with thread, with seal

22150.0431



Product Description

To be used for positioning and applying pressure, e.g. during painting and sandblasting. Sealed against chips and dirt.

Material

Seal

- CR

Body

- Steel, zinc-plated by galvanization

Spring

- Steel, blackened

Pin

- Steel, case-hardened, zinc-plated by galvanization

Assembly

Lateral plungers are installed by screwing in by means of a mounting tool.

Formula for calculating the center distance for the mounting hole:

$$l_0 = z/2 + w + x,$$

l_0 = center distance,

y = workpiece height,

w = workpiece length,

x = coordinate dimension,

s = stroke,

z = stop diameter

Calculation dimension x :

y greater than or equal to $l_2 - d_2/2$, then $x =$

$$d_2/2 - s$$

or

y smaller than $l_2 - d_2/2$, then $x =$

$$d_2/2 - s - [(l_2 - d_2/2 - y) * 0,123]$$

Characteristic

Standard spring load = spring from steel, blackened

Drawing

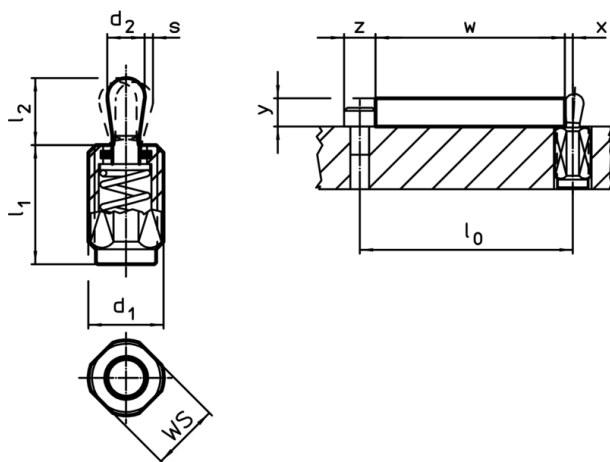

Order information

d ₁	l ₁ -2	Dimensions		d ₂	l ₂	Stroke s	WS	max. [°C]	[g]	Art. No.
		Spring load F max. ¹⁾ ~ [N]	[mm]							
M12	11,5	75	[mm]	6	10	1	10	110	4,8	22150.0431

¹⁾ statistical average value

Accessories

	Dimensions d ₁ [mm]	 [g]	Art. No.
assembly tool			
	M12	76	22150.0820

Application example

