

Lateral Plungers with plastic spring and pin

22150.0238



Product Description

To be used for positioning and applying pressure, e.g. during painting and sandblasting.

Material

Spring

- Plastic

Pin

- Thermoplastic POM, white

Assembly

Moistening the body allows for easier installation.

Installation by pressing in.

Formula for calculating the center distance for the mounting hole:

$$l_0 = z/2 + w + x,$$

l_0 = center distance,

y = workpiece height,

w = workpiece length,

x = coordinate dimension,

s = stroke,

z = stop diameter

Calculation dimension x :

y greater than or equal to $l_2 - d_2/2$, then $x = d_2/2 - s$

or

y smaller than $l_2 - d_2/2$, then $x =$

$$d_2/2 - s - [(l_2 - d_2/2 - y) * 0,123]$$

Characteristic

Standard spring load = red spring

Drawing

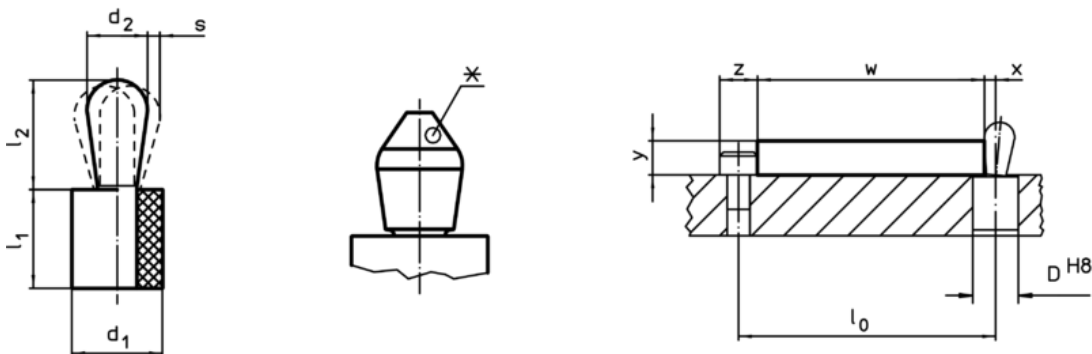



*some sizes (see chart) have a deviating pin shape

Order information

Dimensions		Spring load F max. ¹⁾ ~ [N]	Dimensions		Stroke s [mm]	Location hole D H8 [mm]	🌡️ max. [°C]	📦 [g]	Art. No.
d ₁ [mm]	d ₂ [mm]		l ₁ -1 [mm]	l ₂ ±0,5 [mm]					
10	6	30	9	10,3	1	9,9	80	1	22150.0238

¹⁾ statistical average value

Accessories

	Dimensions d ₁ [mm]	 [g]	Art. No.
assembly tool			
	10	46	22150.0842