

## Lateral Plungers· smooth, with seal

22150.0122



### Product Description

To be used for positioning and applying pressure, e.g. during painting and sandblasting. Sealed against chips and dirt.

#### Material

##### Seal

- CR

##### Body

- Aluminium

##### Spring

- Steel, zinc-plated by galvanization

##### Pin

- Steel, case-hardened, zinc-plated by galvanization

#### Assembly

Installation by pressing in.

Formula for calculating the center distance for the mounting hole:

$$l_0 = z/2 + w + x,$$

$l_0$  = center distance,

$y$  = workpiece height,

$w$  = workpiece length,

$x$  = coordinate dimension,

$s$  = stroke,

$z$  = stop diameter

Calculation dimension  $x$ :

$y$  greater than or equal to  $l_2 - d_2/2$ , then  $x =$

$$d_2/2 - s$$

or

$y$  smaller than  $l_2 - d_2/2$ , then  $x =$

$$d_2/2 - s - [(l_2 - d_2/2 - y) * 0,123]$$

#### Characteristic

Heavy spring load = spring from steel, zinc-plated by galvanization

#### More information

#### Further products

- Eccentric Mounting Bushings, for lateral plungers, smooth

### Drawing

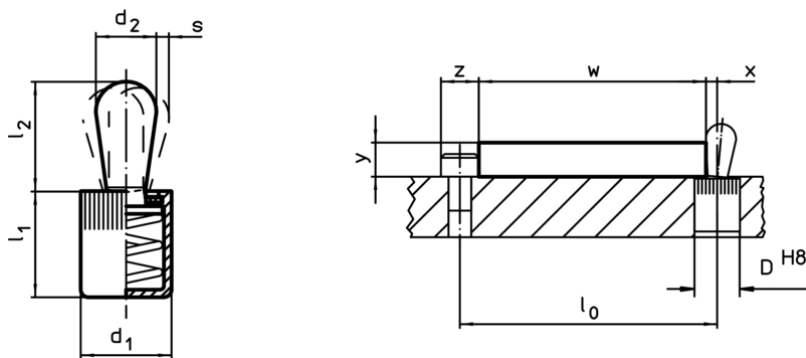



### Order information

Dimensions		Spring load F max. <sup>1)</sup> ~ [N]	Dimensions		Stroke s [mm]	Location hole D H8 [mm]	max. [°C]	[g]	Art. No.
d <sub>1</sub>	d <sub>2</sub>		l <sub>1</sub>	l <sub>2</sub>					
[mm]	[mm]		[mm]	[mm]					
10	5	100	12	6	1,6	10	110	3	22150.0122

<sup>1)</sup> statistical average value

Accessories

	Dimensions $d_1$ [mm]	 [g]	Art. No.
<b>assembly tool</b>			
	10	49	22150.0831

Application example

