

Lateral Plungers· smooth, with seal

22150.0112



Product Description

To be used for positioning and applying pressure, e.g. during painting and sandblasting. Sealed against chips and dirt.

Material

Seal

- CR

Body

- Aluminium

Spring

- Steel, zinc-plated by galvanization

Pin

- Steel, case-hardened, zinc-plated by galvanization

Assembly

Installation by pressing in.

Formula for calculating the center distance for the mounting hole:

$$l_0 = z/2 + w + x,$$

l_0 = center distance,

y = workpiece height,

w = workpiece length,

x = coordinate dimension,

s = stroke,

z = stop diameter

Calculation dimension x :

y greater than or equal to $l_2 - d_2/2$, then $x =$

$$d_2/2 - s$$

or

y smaller than $l_2 - d_2/2$, then $x =$

$$d_2/2 - s - [(l_2 - d_2/2 - y) * 0,123]$$

Characteristic

Heavy spring load = spring from steel, zinc-plated by galvanization

More information

Further products

- Eccentric Mounting Bushings, for lateral plungers, smooth

Drawing

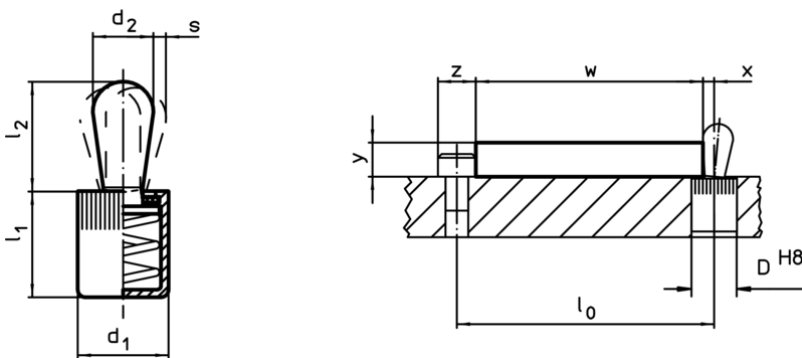

Order information

Dimensions		Spring load F max. ¹⁾ ~ [N]	Dimensions		Stroke s [mm]	Location hole D H8 [mm]	🌡️ max. [°C]	📦 [g]	Art. No.
d ₁	d ₂		l ₁	l ₂					
[mm]	[mm]		[mm]	[mm]	[mm]	[°C]	[g]		
Pin: Steel/heavy spring load									
6	3	40	7	3,7	1	6	110	0,7	22150.0112

¹⁾ statistical average value

Accessories

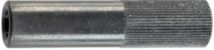
	Dimensions d_1 [mm]	 [g]	Art. No.
assembly tool			
	6	19	22150.0830

Application example

