

## Lateral Plungers· smooth, with seal

22150.0110



### Product Description

To be used for positioning and applying pressure, e.g. during painting and sandblasting. Sealed against chips and dirt.

#### Material

##### Seal

- CR

##### Body

- Aluminium

##### Spring

- Stainless steel

##### Pin

- Steel, case-hardened, zinc-plated by galvanization

#### Assembly

Installation by pressing in.

Formula for calculating the center distance for the mounting hole:

$$l_0 = z/2 + w + x,$$

$l_0$  = center distance,

$y$  = workpiece height,

$w$  = workpiece length,

$x$  = coordinate dimension,

$s$  = stroke,

$z$  = stop diameter

Calculation dimension  $x$ :

$y$  greater than or equal to  $l_2 - d_2/2$ , then  $x =$

$$d_2/2 - s$$

or

$y$  smaller than  $l_2 - d_2/2$ , then  $x =$

$$d_2/2 - s - [(l_2 - d_2/2 - y) * 0,123]$$

#### Characteristic

Light spring load = spring from stainless steel

#### More information

#### Further products

- Eccentric Mounting Bushings, for lateral plungers, smooth

### Drawing

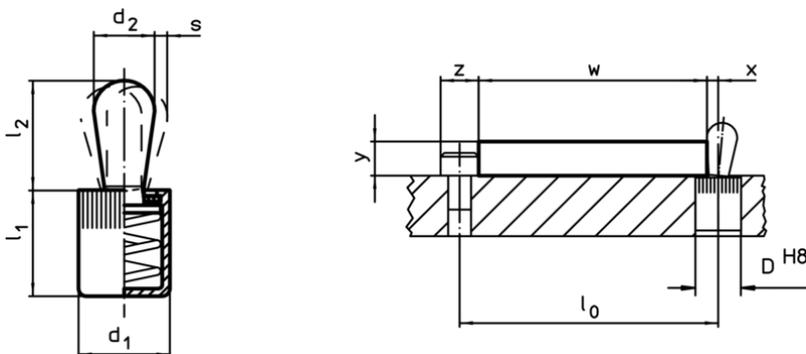

### Order information

Dimensions		Spring load F max. <sup>1)</sup> ~ [N]	Dimensions		Stroke s [mm]	Location hole D H8 [mm]	🌡️ max. [°C]	📦 [g]	Art. No.
$d_1$	$d_2$		$l_1$	$l_2$					
[mm]	[mm]		[mm]	[mm]					
6	3	10	7	3,7	1	6	110	0,6	22150.0110

<sup>1)</sup> statistical average value

Accessories

	Dimensions $d_1$ [mm]	 [g]	Art. No.
<b>assembly tool</b>			
	6	19	<a href="#">22150.0830</a>

Application example

