

Lateral Spring Plungers

22140.0622



Product Description

To be used for positioning and applying pressure, e.g. during painting and sandblasting.

Material

Ball

- Ball-bearing steel, hardened

Body

- Free cutting steel, blackened

Spring

- Plastic (PU)

Assembly

Insertion bore l_3 to be considered.

More information

Notes

Special types on request.

Drawing

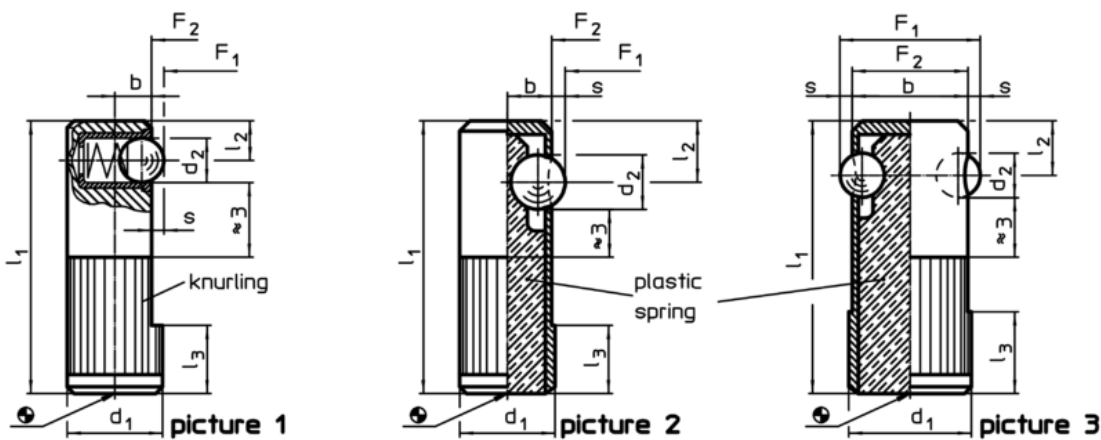

Order information

Dimensions						Location hole H8	Stroke s	Spring load ¹⁾		min. max.	[g]	Art. No.	
d ₁ +0,1	d ₂	l ₁	l ₂	l ₃	b			F ₁	F ₂				
[mm]						[mm]	[mm]	[N]	[N]	[°C]			
ball from ball-bearing steel, heavy spring load, on both sides – picture 3													
22	8	45	9	15	21	22	2,5	130	540	-40	80	45	22140.0622

¹⁾ statistical average value

Application example

