

Lateral Spring Plungers

22140.0618



Product Description

To be used for positioning and applying pressure, e.g. during painting and sandblasting.

Material

- Ball**
 - Ball-bearing steel, hardened
- Body**
 - Free cutting steel, blackened
- Spring**
 - Plastic (PU)

Assembly

Insertion bore l_3 to be considered.

More information

Notes

Special types on request.

Drawing

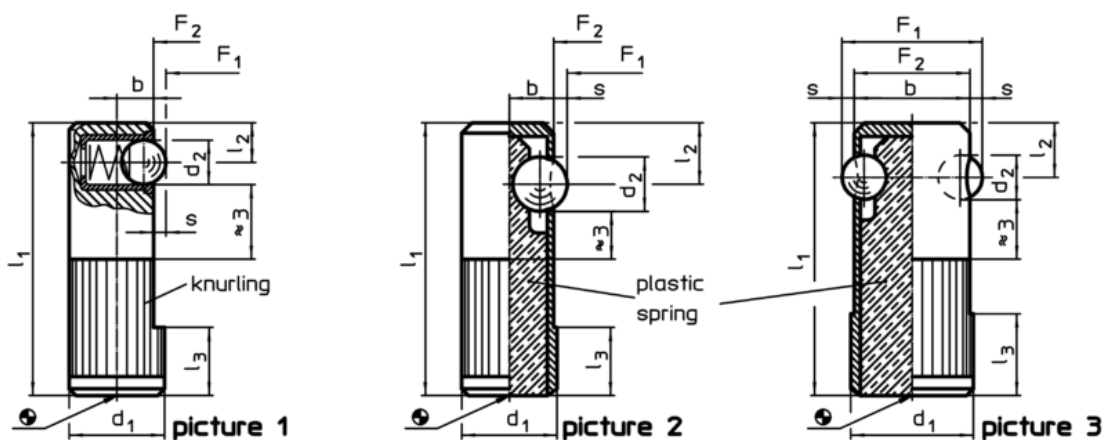

Order information

Dimensions						Location hole H8	Stroke s	Spring load ¹⁾		Temperature		Weight [g]	Art. No.
d ₁ +0,1	d ₂	l ₁	l ₂	l ₃	b			F ₁ ~	F ₂ ~	min.	max.		
[mm]						[mm]	[mm]	[N]		[°C]		[g]	
ball from ball-bearing steel, heavy spring load, on both sides – picture 3													
18	6,5	40	8	12	17	18	1,8	120	330	-40	80	29	22140.0618

¹⁾ statistical average value

Application example

