

Lateral Spring Plungers

22140.0616



Product Description

To be used for positioning and applying pressure, e.g. during painting and sandblasting.

Material

Ball

- Ball-bearing steel, hardened

Body

- Free cutting steel, blackened

Spring

- Plastic (PU)

Assembly

Insertion bore l_3 to be considered.

More information

Notes

Special types on request.

Drawing

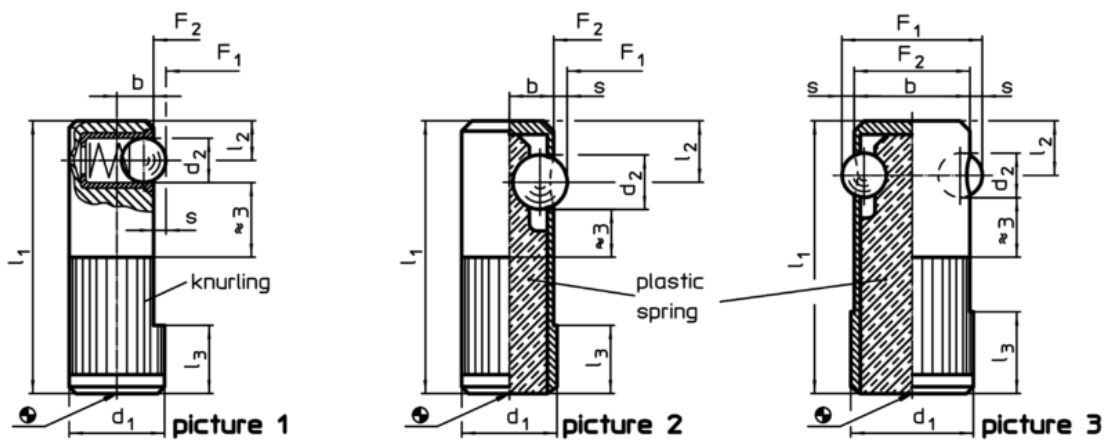

Order information

Dimensions						Location hole H8	Stroke s	Spring load ¹⁾		Temperature		Weight [g]	Art. No.
d_1 +0,1	d_2	l_1	l_2	l_3	b			F_1 ~	F_2 ~	min.	max.		
[mm]						[mm]	[mm]	[N]		[°C]		[g]	
ball from ball-bearing steel, heavy spring load, on both sides – picture 3													
16	5,5	35	7	11	15	16	1,5	110	220	-40	80	21	22140.0616

¹⁾ statistical average value

Application example

